



GOVERNMENT OF TAMILNADU

CURRICULUM AND SYLLABUS

DIPLOMA IN CIVIL ENGINEERING

SEMESTER SYSTEM

K - S C H E M E

2007 - 2008



DIRECTORATE OF TECHNICAL EDUCATION
TAMILNADU

GOVERNMENT OF TAMILNADU
DEPARTMENT OF TECHNICAL EDUCATION
CHENNAI



DIPLOMA PROGRAMME
IN
CIVIL ENGINEERING
SYLLABUS
K – SCHEME – 2007 – '08

DIPLOMA COURSES IN ENGINEERING
(FULL TIME)
SEMESTER SYSTEM
(Implemented from 2007- 2008)
K - SCHEME
REGULATIONS

1. Description of the Course

The Course for the Full time Diploma in Engineering shall extend over a period of three academic years, consisting of 6 semesters and the First Year is common to all Engineering Branches.

Each Semester will have 16 weeks duration of study

The Curriculum for all the 6 Semesters of Diploma Programmes (Engineering & Special Diploma Programmes) have been revised and the revised curriculum is applicable for the candidates admitted from 2007 – 2008 academic year onwards.

The salient features of this revised curriculum under 'K' Scheme are:

- ❖ Removal of obsolete portions
- ❖ Addition of topics covering of new technology, new industrial practices to cope up with the modern trends in Engineering and Services.
- ❖ Inclusion of Professional Ethics
- ❖ Creation of consciousness about Environment Management
- ❖ Preparing the students to tackle emergency situations due to various disasters
- ❖ Adoption of Industrial Safety Practices
- ❖ Offering electives to suit the local needs of industries
- ❖ Laying more stress on Communication English
- ❖ Training in Soft Skills
- ❖ Enhancement of Computer Skills
- ❖ Enhanced Practical Skills to supplement the theory learnt
- ❖ Introduction of Continuous Internal Assessment
- ❖ Conduct of Periodical Tests and Assignments and uniformity in assigning sessional marks
- ❖ Listing of Equipment, Instruments/ manuals along with the Practical Experiments
- ❖ Revised Question Paper pattern to test the in-depth knowledge of students.

2. Eligibility for the Award of Diploma

No candidate shall be eligible for the Diploma unless he/she has undergone the prescribed course of study for a period of not less than 3 academic years in any institution affiliated to the State Board of Technical Education and Training, Tamilnadu, when joined in First Year and two years if joined under Lateral Entry scheme in the second year and has passed the prescribed examination.

3. Subject of study and curriculum outline

The subjects of study shall be in accordance with the syllabus prescribed from time to time, both in theory and practical. The curriculum outline for III, IV, V and VI Semester is given in **Annexure-I**

4. Examinations

Board Examinations in all subjects of all the semesters under the scheme of examinations will be conducted at the end of each semester.

The sessional marks for all the subjects will be awarded on the basis of continuous internal assessment earned during the semester concerned. For each subject 25 marks are allotted for sessional marks and 75 marks are allotted for Board Examination.

5. Continuous Internal Evaluation

For Theory Subjects:

It has been decided to introduce Continuous Internal assessment marks for a total of 25 marks, which are to be distributed as follows:

i) Attendance

5 Marks

(Award of marks for attendance will be as per the range given below)

80% - 83%	1 Mark
84% - 87%	2 Marks
88% - 91%	3 Marks
92% - 95%	4 Marks
96% - 100%	5 Marks

ii) Test

10 Marks

3 Tests each of 2 / 2 ½ hours duration for a total of 30/50 marks are to be conducted out of which the best two will be taken and the marks to be reduced to 10.

<i>TEST</i>	<i>UNITS</i>	<u>WHEN TO CONDUCT</u>	<i>MARKS</i>
Test – I	Unit – I	End of 4 th week	30
Test – II	Unit – II & III	End of 10 th week	50
Test – III	Unit – IV	End of 14 th week	30

Question Paper Pattern for Periodical Test: (Test – I & Test – III)

5 Questions X 1 mark	05 marks
5 Questions X 3 marks	15 marks
1 Question X 10 marks	10 marks
		<u>30 marks</u>

Question Paper Pattern for Periodical Test: (Test – II)

5 Questions X 1 mark	05 marks
5 Questions X 3 marks	15 marks
3 Questions X 10 marks	30 marks
		<u>50 marks</u>

Model Examination covering all 5 units for 75 marks and 3 hrs. duration.

iii) Assignment

10 Marks

For each subject three Assignments are to be given each for 20 marks and the average marks scored should be reduced for 10 marks.

All Test Papers and assignment note books after getting the signature from the students must be kept in the safe custody in the Department for verification and audit. It should be preserved for a Semester for Academic Audit.

For Practical Subjects:

The Sessional mark calculation for Practical subjects is to be done as follows:-

a) Attendance	:	5	Marks - evaluation pattern same as Theory
b) Procedure/ observation and tabulation/ other Practical related Work	:	10	Marks
c) Result	:	5	Marks
d) Record writing	:	5	Marks

TOTAL	:	25	Marks

The Record for every completed exercise should be submitted in the subsequent Practical classes and marks should be awarded for 20 for each exercise as per the above allocation.

At the end of the Semester, the average marks of all the exercises should be calculated for 20 marks and the marks awarded for attendance is to be added to arrive at the Sessional mark for Practical.

All the mark entries for assignment, test and attendance should be entered in the Personal Log Book of the staff, handling the subject. This is applicable to both Theory and Practical subjects.

6. Communication Skill Practicals

The Communication Skill Practical with more emphasis is being introduced in IV Semester for Circuit Branches and in V Semester for other branches of Engineering.

Much Stress is given on:

- ❖ Reading Skill
- ❖ Listening Skill
- ❖ Writing Skill
- ❖ Pronunciation
- ❖ Interview Techniques
- ❖ Writing Resumes

Sessional Mark **.... 25 Marks**

**Board Examination Mark Allocation
Allocation of Marks**

Communication Practical	45 Marks
Written Test in Professional Ethics for 1 Hour			
Selection of 10 Questions (10 X 2 marks)		20 Marks
(with out choice) should be only from the Question Bank to be set by the External Examiner			
Project Report Writing		10 Marks

7. Project Work

The students of all the Diploma Programmes (except Diploma in Modern Office Practice) have to do a Project Work as part of the Curriculum and in partial fulfillment for the award of Diploma by the State Board of Technical Education and Training, Tamil nadu. In order to encourage students to do worthwhile and innovative projects, every year prizes are awarded for the best three projects i.e. institution wise, region wise and state wise. The selection of Project work should be taken up in V Sem. of study. The Project may be reviewed twice during 4 th and 10 th week of VI Semester.

a) Sessional mark for Project Work & Viva Voce:

Project Review I	(VI Sem.)	...	10 marks
Project Review II	(VI Sem.)	...	10 marks
Attendance			<u>05 marks</u>
Total	<u><u>25 marks</u></u>

b) Mark Allocation for Project Work & Viva Voce in Board Examination:

Viva Voce	...	15 marks
Project Report	...	10 marks
Demonstration	...	15 marks
Applicability of the Project	...	<u>05 marks</u>

Total ... 45 marks

c) Written Test Mark (from 3 topics for 1 hour duration) :

i) Entrepreneurship	5 questions X 2 marks	=	10 marks
ii) Environment Management	5 questions X 2 marks	=	10 marks
iii) Disaster Management	5 questions X 2 marks	=	10 marks
			<u>30 marks</u>

Selection of Questions should be from Question Bank by the External Examiner, no choice need be given to the candidates.

8. Scheme of Examinations

The Scheme of examinations for subjects in the III, IV, V and VI Semester are given in **Annexure-II**.

9. Criteria for Pass

- No candidate shall be eligible for the award of Diploma unless he/she has undergone the prescribed course of study successfully in an institution approved by AICTE and affiliated to the State Board of Technical Education & Training, Tamil Nadu and pass all the subjects prescribed in the Scheme of Examination.
- A candidate shall be declared to have passed the examination in a subject if he/she secures not less than 40% in theory/drawing subjects and 50% in practical subjects out of the total prescribed maximum marks including both the sessional and the Board Examination marks put together, subject to the condition that he/she secures at least a minimum of 30 marks out of 75 marks in the Board's Theory/Drawing and a minimum of 35 marks out of 75 marks in the Board Practical Examinations.

10. Classification of successful candidates

Classification of candidates who pass out the final examination from April 2010 onwards (joined in first year in 2007-2008) will be done as specified below:

First Class with Distinction:

A candidate will be declared to have passed in First Class with Distinction if he/she secures not less than 75% of the aggregate marks in all semesters put together, except I and II Semester and passes all the above Semesters in the first appearance itself and completes all papers including that of I & II Semester within the stipulated period of study 3/ 3½/ 4 years (Full Time/Sandwich/Part Time) without any break in study.

First Class

A candidate will be declared to have passed in First Class if he/she secures not less than 60% of the aggregate marks in all semesters put together except I & II Semesters and completes all papers

including that of the I & II Semester within the stipulated period of study 3/ 3½ / 4 years (Full Time/Sandwich/Part Time) without any break in study.

Second Class

All other successful candidates will be declared to have passed in Second Class.

The above mentioned classification is applicable for the Sandwich / Part-Time students who pass out Final Examination from October 2010 /April 2011 onwards (both joined in First Year in 2007-2008)

11. Duration of a period in the Class Time Table

The duration of each period of instruction 1 hour and the total period of instruction hours excluding interval and Lunch break in a day should be uniformly maintained as 7 hours corresponding to 7 periods of instruction (Theory & Practical).

* * *

CURRICULUM AND SCHEME OF EXAMINATION
DIPLOMA IN CIVIL ENGINEERING (FULL TIME) COURSE No::1010)

K-SCHEME (WITH EFFECT FROM 2008-2009)

Total Curriculum Hours : 35 Hours / Week

Total Working Hours : 35 Hours / Week
16 weeks / Semester

III SEMESTER

Sl. No	Subject Code	Subject	Hours Per Week	Scheme of Exam				
				Duration of Exam Hours	IA	BE	Total	Min Marks for Pass*
1	11031	Engineering Mechanics	7	3	25	75	100	40
2	11032	Construction Materials and Practice	6	3	25	75	100	40
3	11033	Surveying	7	3	25	75	100	40
4	11034	Civil Engineering Drawing I	6	3	25	75	100	40
5	11035	Material Testing Lab Practice – I	3	3	25	75	100	50
6	11036	Surveying Practice I	6	3	25	75	100	50

IV SEMESTER

Sl. No	Subject Code	Subject	Hours Per Week	Scheme of Exam				
				Duration of Exam Hours	IA	BE	Total	Min Marks for Pass*
1	11041	Theory of Structures	7	3	25	75	100	40
2	11042	Environmental Engineering	7	3	25	75	100	40
3	11043	Transportation Engineering	6	3	25	75	100	40
4	11044	Material Testing Lab Practice II	3	3	25	75	100	50
5	11045	CAD in Civil Engineering Drawing Practice-I	6	3	25	75	100	50
6	11046	Surveying Practice II	6	3	25	75	100	50

* Minimum marks to be secured in the End Exam (Eligible for Pass) :
30 marks out of 75 marks in the Board's Theory/Drawing Examinations.
35 marks out of 75 marks in Board Practical Examinations.

V SEMESTER

Sl. No	Subject Code	Subject	Hours Per Week	Scheme of Exam				
				Duration of Exam Hours	IA	BE	Total	Min Marks for Pass*
1	11051	Structural Engineering	7	3	25	75	100	40
2	11052	Quantity Surveying	7	3	25	75	100	40
3	11071	Elective Theory I a. Concrete Technology and Advanced Construction	5	3	25	75	100	40
	11072	b. Elements of Interior Design						
4	11054	CAD in Civil Engineering Drawing Practice-II	6	3	25	75	100	50
5	11055	Construction Lab Practice	6	3	25	75	100	50
6	11011	English Communication Practical	4	3	25	75	100	50

VI SEMESTER

Sl. No	Subject Code	Subject	Hours Per Week	Scheme of Exam				
				Duration of Exam Hours	IA	BE	Total	Min Marks for Pass*
1	11061	Construction Management with MIS	7	3	25	75	100	40
2	11062	Hydraulics	7	3	25	75	100	40
3	11081	Elective Theory II a. Town Planning	6	3	25	75	100	40
	11082	b. Water Resource Management						
4	11064	Hydraulics and Plumbing Lab Practice	3	3	25	75	100	50
5	11065	Computer Application in Civil Engineering	6	3	25	75	100	50
6	11066	Project Work	6	3	25	75	100	50

* Minimum marks to be secured in the End Exam (Eligible for Pass) :
 30 marks out of 75 marks in the Board's Theory/Drawing Examinations.
 35 marks out of 75 marks in Board Practical Examinations.

1053 - Elective Theory I

11071 a. Concrete Technology and Advanced Construction
 11072 b. Elements of Interior Design

1063 - Elective Theory II

11081 a. Town Planning
 11082 b. Water Resource Management

CURRICULUM AND SCHEME OF EXAMINATION
DIPLOMA IN CIVIL ENGINEERING (PART TIME) (COURSE No::3010)
K-SCHEME (WITH EFFECT FROM 2008-2009)

Total Curriculum Hours : 18 Hours / Week

Total Working Hours : 18 Hours / Week
16 weeks / Semester

III SEMESTER

Sl. No	Subject Code	Subject	Hours Per Week	Scheme of Exam				
				Duration of Exam Hours	IA	BE	Total	Min Marks for Pass*
1	11031	Engineering Mechanics	4½	3	25	75	100	40
2	11033	Surveying	4½	3	25	75	100	40
3	12005	Engineering Graphics (first year)	3	3	25	75	100	40
4	11035	Material Testing Lab Practice– I	3	3	25	75	100	50
5	11036	Surveying Practice I	3	3	25	75	100	50

IV SEMESTER

Sl. No	Subject Code	Subject	Hours Per Week	Scheme of Exam				
				Duration of Exam Hours	IA	BE	Total	Min Marks for Pass*
1	11032	Construction Materials and Practice	4½	3	25	75	100	40
2	11043	Transportation Engineering	4½	3	25	75	100	40
3	11034	Civil Engineering Drawing I	3	3	25	75	100	40
4	11046	Surveying Practice II	3	3	25	75	100	50
5	12008	Computer Application Lab(first Year)	3	3	25	75	100	50

* Minimum marks to be secured in the End Exam (Eligible for Pass) :
30 marks out of 75 marks in the Board's Theory/Drawing Examinations.
35 marks out of 75 marks in Board Practical Examinations.

V SEMESTER

Sl. No	Subject Code	Subject	Hours Per Week	Scheme of Exam				Min Marks for Pass*
				Duration of Exam Hours	IA	BE	Total	
1	11041	Theory of Structures	6	3	25	75	100	40
2	11042	Environmental Engineering	4½	3	25	75	100	40
3	11044	Material Testing Lab Practice - II	3	3	25	75	100	50
4	11011	English Communication Practical	4½	3	25	75	100	50

VI SEMESTER

Sl. No	Subject Code	Subject	Hours Per Week	Scheme of Exam				Min Marks for Pass*
				Duration of Exam Hours	IA	BE	Total	
1	11051	Structural Engineering	6	3	25	75	100	40
2	11071 11072	Elective Theory I a. Concrete Technology and Advanced Construction b. Elements of Interior Design	4½	3	25	75	100	40
3	11045	CAD in Civil Engineering Drawing Practice – I	3	3	25	75	100	50
4	11055	Construction Lab Practice	4½	3	25	75	100	50

VII SEMESTER

Sl. No	Subject Code	Subject	Hours Per Week	Scheme of Exam				Min Marks for Pass*
				Duration of Exam Hours	IA	BE	Total	
1	11052	Quantity Surveying	6	3	25	75	100	40
2	11062	Hydraulics	6	3	25	75	100	40
3	11064	Hydraulics and Plumbing Lab Practice	3	3	25	75	100	50
4	11054	CAD in Civil Engineering Drawing Practice – II	3	3	25	75	100	50

* Minimum marks to be secured in the End Exam (Eligible for Pass) :
 30 marks out of 75 marks in the Board's Theory/Drawing Examinations.
 35 marks out of 75 marks in Board Practical Examinations.

VIII SEMESTER

Sl. No	Subject Code	Subject	Hours Per Week	Scheme of Exam				
				Duration of Exam Hours	IA	BE	Total	Min Marks for Pass*
1	11061	Construction Management with MIS	6	3	25	75	100	40
2	11081 11082	Elective Theory II a. Town Planning b. Water Resource Management	6	3	25	75	100	40
3	11065	Computer Applications in Civil Engineering	3	3	25	75	100	50
4	11066	Project Work	3	3	25	75	100	50

1053 - Elective Theory I

11071 a. Concrete Technology and Advanced Construction
11072 b. Elements of Interior Design

1063 - Elective Theory II

11081 a. Town Planning
11082 b. Water Resource Management

* Minimum marks to be secured in the End Exam (Eligible for Pass) :
30 marks out of 75 marks in the Board's Theory/Drawing Examinations.
35 marks out of 75 marks in Board Practical Examinations.

* * *

**EQUIVALENT PAPERS
for
DIPLOMA IN CIVIL ENGINEERING**

SI.No	J- SCHEME		K - SCHEME	
	Code No	Subject Name	Code No	Subject Name
III SEMESTER				
1	1031	Engineering Mechanics	11031	Engineering Mechanics
2	1032	Construction Materials and Practice	11032	Construction Materials and Practice
3	1033	Surveying	11033	Surveying
4	1034	Civil Engineering Drawing I	11034	Civil Engineering Drawing I
5	1035	Material Testing Lab Practice - I	11035	Material Testing Lab Practice – I
6	1036	Surveying Practice I	11036	Surveying Practice I
IV SEMESTER				
7	1041	Theory of Structures	11041	Theory of Structures
8	1042	Hydraulics	11062	Hydraulics
9	1043	Transportation Engineering	11043	Transportation Engineering
10	1044	Hydraulics Lab Practice	11064	Hydraulics and Plumbing Lab Practice
11	1045	CAD in Civil Engineering Drawing Practice	11045	CAD in Civil Engineering Drawing Practice-I
12	1046	Surveying Practice II	11046	Surveying Practice II
V Semester				
13	1051	Structural Engineering	11051	Structural Engineering
14	1052	Estimating and Costing	11052	Quantity Surveying
15	1063	Elective Theory I 1053 a. Elements of Interior Design 1053 b. Advanced Construction Technology 1053 c. Soil Mechanics and Foundation Engineering	11072.b 11071.a -	Elements of Interior Design Concrete Technology and Advanced Construction No Equivalent Paper

16	1054	Civil Engineering Drawing II	11054	CAD in Civil Engineering Drawing Practice-II
17	1055	Computer Application in Civil Engineering	11065	Computer Application in Civil Engineering
18	1056	Material Testing Lab Practice II	11044	Material Testing Lab Practice II
VI SEMESTER				
19	1061	Construction Management and Entrepreneurship	11061	Construction Management with MIS
20	1062	Environmental Engineering and Pollution control	11042	Environmental Engineering
21	1063	Elective Theory II 1063 a. Irrigation Engineering 1063 b. Town Planning 1063 c. Advanced RC concrete Structures	11082.b 11081.a 11051	Water Resource Management Town Planning Structural Engineering
22	1064	Environmental Engineering Lab Practice.	11055	Construction Lab Practice
23	1065	Construction Lab Practice	11055	Construction Lab Practice
24	1066	Project Work	11066	Project Work
PART - TIME				
25	1002	Basics of Computer Science		No Equivalent paper
26	1007	Technical Drawing	11007	Engineering Graphics

Curriculum and Scheme of Examinations
Diploma in Civil Engineering (Sandwich (COURSE No::2010)
K - Scheme

Total curriculum hours: 35 hours/week

Total Working hours: 35 hours/week
 16 Hours / Week

III SEMESTER

Sl. No	Subject Code	Subject	Hours Per Week	Scheme of Exam				
				Duration of Exam Hours	IA	BE	Total	Min Marks for Pass*
1	11031	Engineering Mechanics	6	3	25	75	100	40
2	11032	Construction Materials & Practice	5	3	25	75	100	40
3	11033	Surveying	5	3	25	75	100	40
4	11034	Civil Engineering Drawing- I	5	3	25	75	100	40
5	11043	Transportation Engineering	5	3	25	75	100	40
6	11035	Material Testing Lab practice I	3	3	25	75	100	50
7	11036	Surveying Practice I	6	3	25	75	100	50

IV SEMESTER

Sl. No	Subject Code	Subject	Hours Per Week	Scheme of Exam				
				Duration of Exam Hours	IA	BE	Total	Min Marks for Pass*
1	11045	CAD in Civil Engineering Drawing Practice - I	6	3	25	75	100	50
2	11047	In plant Training		3	25	75	100	40

* Minimum marks to be secured in the End Exam (Eligible for Pass) :
 30 marks out of 75 marks in the Board's Theory/Drawing Examinations.
 35 marks out of 75 marks in Board Practical Examinations.

V SEMESTER

Sl. No	Subject Code	Subject	Hours Per Week	Scheme of Exam				
				Duration of Exam Hours	IA	BE	Total	Min Marks for Pass*
1	11041	Theory of Structures	6	3	25	75	100	40
2	11062	Hydraulics	5	3	25	75	100	40
3	11052	Quantity Surveying	6	3	25	75	100	40
4	11071 11072	Elective Theory I a. Concrete Technology and Advanced Construction b. Elements of Interior Design	4	3	25	75	100	40
5	11044	Material Testing Lab practice II	2	3	25	75	100	50
6	11046	Surveying Practice II	5	3	25	75	100	50
7	11054	CAD in Civil Engineering Drawing Practice - II	5	3	25	75	100	50
8	11064	Hydraulics and Plumbing Lab	2	3	25	75	100	50

VI SEMESTER

Sl. No	Subject Code	Subject	Hours Per Week	Scheme of Exam				
				Duration of Exam Hours	IA	BE	Total	Min Marks for Pass*
1	11051	Structural Engineering	6	3	25	75	100	40
2	11042	Environmental Engineering	5	3	25	75	100	40
3	11061	Construction Management with MIS	5	3	25	75	100	40
4	11081 11082	Elective Theory II a. Town Planning b. Water Resource Management	5	3	25	75	100	40
5	11065	Computer Application in Civil Engineering	6	3	25	75	100	50
6	11055	Construction Lab Practice	3	3	25	75	100	50
7	11011	English Communication Practical	5	3	25	75	100	50

* Minimum marks to be secured in the End Exam (Eligible for Pass) :
 30 marks out of 75 marks in the Board's Theory/Drawing Examinations.
 35 marks out of 75 marks in Board Practical Examinations.

VII SEMESTER

Sl. No	Subject Code	Subject	Hours Per Week	Scheme of Exam				
				Duration of Exam Hours	IA	BE	Total	Min Marks for Pass*
1	11066	Project Work	6	3	25	75	100	40
2	11074	In plant Training		3			100	50

1053 - Elective Theory I

11071 a. Concrete Technology and Advanced Construction

11072 b. Elements of Interior Design

1063- Elective Theory II

11081 a. Town Planning

11082 b. Water Resource Management

* Minimum marks to be secured in the End Exam (Eligible for Pass) :
30 marks out of 75 marks in the Board's Theory/Drawing Examinations.
35 marks out of 75 marks in Board Practical Examinations.

III-SEMETER

11031 – ENGINEERING MECHANICS

7 Hrs/Week

16 Weeks

112 Hours

OBJECTIVES:

- Define Mechanical Properties of materials and different type of stress and strain.
- Understand the applications of stress and strain in engineering field.
- Analyse, determinate beams and sketch S.F. and B.M. diagram.
- Locate the position of centroid of different geometrical section and Built up section determine I_{xx} , I_{yy} , Z_{xx} , Z_{yy} of different geometrical section & built up sections.
- Derive simple bending eqm. and understand its applications.
- Derive Torsional equation and understand its applications.
- Analyse Pin Jointed Frames analytically and graphically.
- Solve simple problems in the course of study.

UNIT 1 – SIMPLE STRESSES AND STRAIN

20 Hours

1.1 Introduction

Importance of study of Engineering Mechanics / Strength of materials. Mechanical properties of materials – Elasticity, Plasticity, Hardness, Toughness, Brittleness, Ductility, Creep, Fatigue.

1.2 Stress and strain

Force-definition-Types of forces acting on a structural member-Definition of tension, compression, shear; Stress-strain-definition-Different types of stresses-tensile, compressive and shear stresses - Different types of strains –Tensile, Compressive and Shear strains; Longitudinal and Lateral strains-Poisson's Ratio- Numerical problems on stress and strain.

1.3 Moduli of Elasticity / Elastic constants

Elasticity –Elastic limit- Hooke's law – Young's modulus of Elasticity –Rigidity modulus-Volumetric strain – Bulk modulus – Definition-Relation between three Moduli-derivation-Young's modulus for selected engineering materials- Numerical problems.

1.4 Application of stress and strain in engineering field

Deformation of prismatic bars subjected to uniaxial load- Deformation of stepped bars- Deformation of prismatic bars due to self weight- Numerical problems.

1.5 Behavior of ductile and brittle material

Load extension curve of ductile and brittle material – Limit of proportionality, Elastic limit, Yield stress, Ultimate stress, Breaking stress, Factor of safety, Significance of percentage of elongation and reduction in area-Numerical problems.

1.6 Composite Beams / Sections

Definition – Assumptions made – Principles of analysis stress developed in Composite section and R.C.C. sections – Problems.

UNIT 2 – SHEAR FORCE AND BENDING MOMENT

20 Hours

2.1 Introduction

Definition of a beam and reaction – Support conditions and diagrammatic representation – Types of beams based on support conditions – Diagrammatic representation of beams – Static equilibrium equations – Determinate and indeterminate beams.

2.2 Loads

Transverse loads-Types (Concentrated, uniformly distributed and varying loads)-Diagrammatic representation of beams with different loads.

2.3 Shear force and Bending Moment

Definition – Conventional signs used for S.F. and B.M – S.F and B.M of determinate beams – S.F and B.M diagrams-Significance of point of contra flexure-Relation between intensity of load S.F and B.M. – Numerical problems on S.F and B.M.(Determinate beams with concentrated loads and udl only)

UNIT 3 – GEOMETRICAL PROPERTIES OF SECTIONS

20 Hours

3.1 Centroid:

Geometrical properties -Definition of centroid and center of gravity – Centroid of regular geometrical figures-Centroid of symmetric, symmetric, and anti symmetric practical sections-Built up structural sections-Numerical problems.

3.2. Moment of Inertia:

Definition and notation of Moment of Inertia, Polar moment of inertia, Radius of gyration, section modulus and polar modulus, Parallel and perpendicular axes theorems; M.I. of regular geometrical plane sections (rectangular, triangular and circular sections) – M.I. about centroidal axis-MI about base, Radius of gyration- section modulus- Polar moment of inertia – Polar modulus- Numerical problems- MI of symmetric, asymmetric, antisymmetric and built up sections – Numerical problems.

UNIT 4 – STRESS IN BEAMS AND SHAFTS

20 Hours

4.1. Stresses in Beams due to bending:

Introduction-Bending stress-Neutral axis-Theory of simple bending-Assumption- Moment of resistance – Bending stress distribution – curvature of beam – Derivation of flexure equation $M / I = E / R = \sigma / Y$ – Position of N.A and centroidal axis-Stiffness equation- Flexural rigidity- Definition and significance-Strength equation- Section modulus- Definition and significance- Numerical problems.

4.2. Stress in shafts due to torsion:

Introduction-Couple-Torque (or) Twisting moment-Assumptions-Shear stress distribution in circular section due to torsion-Derivation of torsion equation $T / J = \tau / R = \theta / l$ – Strength and stiffness of shafts – Torsional rigidity-Torsional modulus- Power transmitted by a shaft – comparative analysis of hollow and solid shafts – Numerical problems.

UNIT 5 – PIN JOINTED FRAMES

20 Hours

5.1. Introduction

Frame / truss- definition-Determinate and indeterminate frames-Classification of frames- Perfect and imperfect frames-Deficient and redundant frames-Formulation of a perfect frame-Common

types of trusses-Support conditions-Resolution of a force-Designation of a force-Nature of forces in a frame- Analysis-Assumptions- Methods of analysis.

5.2 Analytical method

Types of analysis-method of joints versus method of sections-Analysis of simple cantilever and simply supported determinate trusses with nodal concentrated vertical loads- Numerical problems by method of joints only for vertical loads – Identification of zero force members of a determinate truss.

5.3. Graphical Method

Introduction-Space diagram-Bow's notation-Resultant force- Equilibrant force vector diagram-Determination of forces in a cantilever / simply supported determinate truss with vertical load only.

Test & Revision

12 Hours

REFERENCE BOOKS

- S.B.Junnarkor," Mechanics of Structures Vol.I", 17th Edition,
V.Natarajan , " Elements of Applied Mechanics", Oxford & IBH Publishers
Vazirani & Ratwani,"Analysis of Structures Volume I",Khanna publishers,17th ,2003
Dr.N.V.Arunachalam, Textbook of graphics Statics
S.Ramamirtham ,"Strength of materials", Dhanpat Rai, 14th Edition,2003.
Timoshenko and Young," Elements of strength of materials", CBS Publications
R.S.Khurmi," Strength of materials", S.Chand & company, 2nd Edition,1979.
S.A.Urry," Solution of problems in strength of materials", Sir. Isaac Pitman & sons Ltd.
R.L.Jindal," Elements of Theory of structures", S.Chand & company, 2nd Edition,1970.
Dr.A.Elangovan , " Engineering mechanics Tamil version", - Anna University

* * *

11032-CONSTRUCTION MATERIALS AND PRACTICE

6 Hrs/Week

16 Weeks

96 Hours

OBJECTIVES:

- State different construction materials and their properties.
- Explain different types of cement grades of cements and tests on cement.
- State and explain different types of modern building materials such as ceramic products, glass, metals and plastics.
- Explain method of preparation of mortar cement concrete.
- State the different types of structures.
- Describe the different types of foundations.
- Describe the classification of stone masonry & brick masonry.
- State different types of doors, windows, lintels & stairs.
- Describe the types of floors and roofs.
- Describe the different methods of pointing, plastering and termite proofing.
- Explain the methods of scaffolding, shoring & underpinning and form work.
- Describe procedure of colour washing and white washing.

A. Construction Materials

UNIT 1

16 Hours

1.1 Introduction :

Physical properties of materials – Density, Bulk density, Specific gravity, porosity, water absorption, permeability, chemical resistance, fire resistance, weathering resistance, thermal capacity, Durability. (Definitions only)

1.2 Rocks and Stones :

Rocks – classification of Rocks – Geological, Physical and Chemical classification – uses of stones – Requirements of a good building stone – Natural stones for flooring – Cuddappa slabs, Kota stone, sand stone, Shahabad stone, Granite, Marble – Artificial stones.

1.3 Bricks :

Definition – Brick earth – Composition of good brick earth – Manufacturing process – classification of bricks – properties of bricks – special types of bricks and their uses – compressive strength of bricks - grade of bricks as per BIS

1.4 Lime and Pozzolanas :

Sources of lime – classification lime – Fat, Hydraulic and Poor lime - uses of lime
Pozzolanic materials – Surki, Flyash, Ground blast furnace slag, Rice husk ash – Advantages of addition of pozzolanas

1.5 Cement :

Definition – Composition of ordinary Portland cement – Functions of cement ingredients – Different types of cements – Grades of cement (33,43 and 53) –Storage of cement - Tests of cement – objects of each test – Test requirements/ BIS specifications of OPC - Admixtures – Definition – uses .

1.6 Ceramic Products :

Definition – Earthenware , Stoneware , Porcelain , Terracotta, Glazing, Tiles (Definitions only) – Types of Tiles – Clay Terracing tiles – Glazed Ceramic tiles – Fully Vitrified tiles – Roof tiles – Sanitary appliances

1.7 Timber and Timber Products :

Types Timber – Teak, Sal, Rosewood, Mango, and Jack – Defects in timber – seasoning of timber - objectives – Timber Products – Veeners , Ply woods , Particle Board , Fibre board, Hard board, Block board, Laminated board.

Curtain Wall:

Definition of Curtain wall – Purpose of providing Curtain walls -Types, Advantages and Disadvantages of different materials used (Glass panels, Metal claddings, Artificial Panel Boards, Structural Glass) - Strength requirements - Dead load, Wind load, Seismic load, Thermal load, Blast load, Erection load - Serviceability requirements – Aesthetic appearance, Thermal radiation, Air Filtration & Water penetration - Sealing methods - Maintenance & Repair.

UNIT 2

17 Hours

2.1 Mortar:

Definition – Properties and uses of mortar – Types of mortar – Cement and Lime mortar – Preparation of cement mortar.

2.2 Concrete:

Definition – Constituents of concrete and their requirements – uses of concrete – Types of concrete , Lime concrete, cement concrete and light weight concrete – Preparation of cement concrete – Hand mixing , Machine mixing and Ready mix concrete – Compaction of concrete – Methods – Curing of concrete – Methods.

2.3 Paints and Varnishes :

Definition – Functions of paint – Types of paints - Oil, Enamel, Emulsion, Distemper, Cement, Aluminium, Bituminous and Plastic paints – Process of painting – Preparation of surface and application – New woodwork, steel structure and wall surface – Defects in painting and remedies – Varnishes – Definition – Characteristics of a good varnish – Ingredients of varnish – Types of varnish –Oil, Turpentine , Spirit and water varnish - preparation of surface and application of varnish .

2.4 Glass :

Definition – Constituents of glass – Classification of glass – Functions and Utility – Types of glass – sizes and thickness – uses in Buildings.

2.5 Metals and Plastics :

Types of metals used in construction _ Cast Iron ,Steel, Aluminium –Market forms of steel – Steel for reinforced concrete - steel for prestressed concrete –Hot rolled steel sections – cold formed light gauge section.- Plastics – Characteristics and Uses of plastics – Types – Thermo plastics and Thermosetting plastics – Various products – plastic pipes, doors, windows, water tanks – sizes , capacity and uses - Advantages of plastics - Asbestos - uses of asbestos.

B. Construction Practice

UNIT 3

17 Hours

3.1. Introduction

Sub structure – super structure – load bearing structure – framed structure – concept of framed structure – advantages of framed structure.

3.2 Foundation

Definition – objectives of foundation – Bearing capacity of soil – Definition – maximum/ultimate and safe bearing capacity of soil bearing capacity of different types of soil – Factors affecting bearing capacity – Requirements of a good foundation – Types of foundation – Shallow foundation – Spread foundation, Isolated column footing, combined footing, continuous footing, Raft foundation – Deep foundation – pile – Types of piles – Bearing pile, Friction pile, undreamed pile – Causes of failure of foundation – Remedial measures.

3.3 Stone masonry

Definition – Common terms used – Natural bed, Sill, corbel, course, cornice, coping, weathering, throat, spalls, quoins, string course, lacing course, through stone, plinth, jambs – Classification of stone masonry – Rubble masonry – Coursed, un coursed & Random rubble masonry – Ashlarmasonry – Type – Ashlar fine, chamfered and facing – points to be considered in the construction of stone masonry – Tools used – Trowel, square, sprit level, plumb bob, chisel line & pins, spall hammer, punch, pitching tool.

3.4 Brick masonry

Definition – Common terms used – Header, stretcher, bed joint, lap, per pends, closer, king, queen & beveled, bat – permissible loads in brick masonry. Bond - Types – Header, stretcher and English bond – one brick thick and one and a half brick tile – ‘T’ junction in English bond – Points to be considered in the construction of brick masonry – Cavity bond masonry- Defects in brick masonry – Maintenance of brick masonry – Hollow concretes(Hollow Block) masonry – Construction of walls (As per C.P.W.D. Specifications)– Advantages of hollow concerts masonry – Rein forced brick masonry – purpose – Reinforced masonry walls – Masonry reinforced columns.

3.5 Partition

Definitions Requirements of a good partition walls – Types – Brick, Concrete, glass, Aluminum frame with Glass sheet, timber, straw board, wood wool, Asbestos Cement board and plastic board partitions.

3.6 Water Proofing and Damp Proofing Material:

Dampness – Causes of dampness – Effects of dampness - Damp proofing – Damp proof courses (DPC) — Materials used for damp proofing (D.P.C) –Properties and functions of various types of water proofing materials commonly available – Admixtures for cement mortar

and cement concrete – Functions of Admixtures – Accelerators, Retarders, Air repelling chemicals – Method of mixing – Bad effects of excessive Admixtures in RCC.

3.7 Advanced Water Proofing Systems:

Advanced materials and Application methods – Terrace protection with Bitumen layer – Various sizes and Thickness of Bitumen sheets – Preparation of surface – Method of Application – Maintenance - Wall protection from Dampness – Use of water proofing chemicals in cement mortars – Special primers and paints – Ingredients used in paints for water proofing, water repelling – Filler material for Cracks - Floor & wall protection from Capillary water pressure – Damp proof course / Grade Beams above ground level – Dadoing of Bathroom and Kitchen walls – Sealing of Floor concrete with Ellis pattern layer – Different materials used.

UNIT 4

17 Hours

4.1 Doors, Windows and ventilators

Standard sizes of doors and windows – Location of doors and windows – Different materials used – Doors – Component parts – Types – Framed and paneled – gazed, flush, louvered, collapsible, rolling shutter and sliding doors – Windows – Types – Casement, Glazed, Bay, Corner – pivoted Circular and dormer windows – Ventilators Definition – purpose – Types – Mosquito proof – Ventilator combined with window / doors.

4.2 Hollow Block and Ferro Cement Constructions :

Hollow blocks – Advantages of hollow blocks – load bearing and non load bearing hollow blocks – Open cavity blocks – face shells, web, gross area, nominal dimensions of blocks, minimum thickness of face shells and web, grades of hollow concrete blocks as per IS2185 (Part – 1) – Materials used, admixtures added – mixing, moulding, placing and compacting, curing, drying – Physical requirements – Use of light weight aggregates (IS2185 – Part – 2) – Autoclaved cellular concrete blocks – Principle of manufacture and advantages of autoclaved cellular blocks (IS2185 – Part 3)

Ferro cement – Properties of materials used – Minimum reinforcement – Admixtures – Mix proportions – Strength requirements – Construction of ferrocement water tanks (IS: 13356 – 1992) – Ferro cement fins, drops, manhole covers, sun shades, shelf etc.

IS 2185 – Part I – Hollow & Solid Conc. Blocks

IS 2185 – Part II – Hollow & Solid Light Wt Conc. Blocks

Part III – Autoclaved Cellular Aerated Conc. Blocks

IS 13358 – 92 – Pre cast Ferro cement water tanks.

4.3. Stairs

Definition – Terms used – Location of stair – types – Straight, Dog legged, Open well, bifurcated and spiral stairs – Moving stairs (Escalators) – Lift.

4.4 Floors and flooring

Floors - Definition – Types – Timber; Composite, RCC floors. Flooring - Definition- Materials used – Selection of flooring – types – Construction Methods(As per C.P.W.D. Specifications)- Mosaic, Granolithic, Tiled, Granite, Marble, Pre cast concrete flooring, Plastic & PVC tile flooring – Carpet tile & Rubber flooring.

4.5 Roof

Definition – Technical terms used – Flat roof – RCC roof – Pitched roof – Terms used in pitched or sloping roof (terms only) – Steel roof truss – Technical terms in roof truss – Types – King post

– Raised chord – Howe truss – Fan flink – north light – Modified north light – (figures only) – Roof Coverings – Mangalore tiles – AC Sheets – PVC Sheets. Shell roof – Advantages – Types – Single parallel- Multi parallel - continuous parallel.

4.6 Weathering Course

Weathering course –Purpose-Materials Required- Brick Jelly Concrete preparation – Laying procedure- Beating methods- Preparation of mortar with Damp Proof materials for laying clay tiles- Pointing and finishing of laid clay tiles.(All procedures are as per C.P.W.D Specifications)

UNIT 5

17 Hours

5.1 Pointing

Objectives – Mortar for pointing – Methods of pointing(As per C.P.W.D. Specifications)
– Types of pointing – Flush, recessed, weathered, keyed or grooved pointing. (As per C.P.W.D. Specifications).

5.2 Plastering

Definitions – Objectives – Cement mortars for Plastering - Requirements of a good plaster – Methods of Plastering(As per C.P.W.D. Specifications) - Defects in plastering.

5.3 External & Internal finishes

Stucco plastering – Special materials used in plastering – Acoustic plasters – Granites silicon plasters – Barium plaster – Asbestos marble plaster – Sand faced – Pebbledash – Wallpapers – Wall tiling.

5.4 White washing, Colour washing & distempering

Whitewashing – preparation of surface – Application of whitewash – Colour washing - Distempering – Preparation of surfaces – Application of distemper(As per C.P.W.D. Specifications)

5.5 Termite proofing

Definition – Methods of termite proofing.

5.6 Scaffolding, Shoring and Under Pinning

Scaffolding – Definition – Component parts – Types – Single, double & Steel scaffolding, Shoring – Definition – Types – Raking, flying and dead shores – Underpinning definition – Purpose – Types – Pit Methods – Pile Method.

5.7 Form work

Definition – Materials used Requirements of a good form work – Form work for column, RC beams and RC slab.

Test & Revision

12 Hours

Reference Books:

- P.C.Varghese, “Building Materials”, Prentice-Hall of India (P) Ltd., I Edition, 2006.
S.K.Duggal, “Building Materials”, New Age International (P) Ltd., II Edition, 2003.
S.C.Rangwala, “ Building Materials”,Charotar Publishing House, VII Edition, 1982.

R.K.Rajput, "Engineering Materials" , S.Chand &Company Ltd., III Re Edition, 2006.
Dr. B.C. Punmia, "Building Construction", Laxmi publications (p)Ltd New Delhi.
Gurucharan singh, "Building Construction ", Standard book house.
S.P. Arora & S. P. Bindra, "Building Construction", Dhanpat rai publications.
S.C.Rangwala, " Building Construction",Charotar Publishing House, VII Edition, 1982.

11033 - SURVEYING

7 Hours / Week

16 Weeks

112 Hours

Objectives:

- Explain the principle of surveying
- Enumerate the instruments used in Surveying
- State different types of Levels and different methods of levelling.
- Computation of Areas, Simple problems using Trapezoidal rule and Simpson's rule.
- Define contour and Explain different methods of contouring.
- State the different types of curves and elements of a simple circular curve.
- Identify the different components and their functions of a Theodolite.
- State and explain the principle of Tachometry and solve simple problems
- Features of Total Station
- Fundamental & components of GIS

UNIT- 1

22 Hours

Introduction

1.1 Definition – Object of surveying – Division of Surveying – Plane and geodetic Survey – Classification of Surveys.

1.2 Chain Surveying

Instruments used for chaining – Chain – Types – Ranging – Base line – Check line – Tie line – Offsets – Types of offsets. -(Description only).

1.3 Compass Surveying

Bearing –Fore and Back bearing – True meridian - Dip and Declination – Prismatic compass-traverse –Designation bearing-Whole circle bearing and Reduced bearing-Simple Problems - Local attraction-(Description only).

1.4 Levelling

Levelling- Definitions – levels – Parts - Functions–Types of levels - Dumpy level – Modern Tilting Levels – Quick setting levels - Automatic and laser level – Leveling staff - Types – Component parts of a levelling instrument - Temporary adjustment – Balancing Back Sight & Fore Sight -Inter sight – Change point – Bench mark – Height of instrument - Reduction of levels – Methods- Height of collimation and Rise and Fall method – Problems-Curvature and Refraction (No problem) -Simple levelling–Fly leveling -Check leveling -Problems- Profile and Cross sectional levelling.

UNIT- 2

20 Hours

2.1 Theodolite

Type of Theodolite – Transit and non -Transit theodolite – Vernier and Micrometer Theodolite – Electronic Theodolite principles (Description only) – Component Parts of Theodolite – Functions

– Technical terms used in Theodolite survey – Temporary adjustment – Fundamental lines – Relation between them – Measurement of Horizontal angle and vertical angle – Latitude and Departure – Consecutive coordinates – Independent coordinate – Computation of Area of closed traverse problems – Omitted measurements (Length and Bearing of One side Omitted Only)– problems.

2.2 Trigonometrical Levelling

Finding elevation of objects – Base accessible – Base in accessible – Single plane & Double plane methods - Simple problems

UNIT-3

18 Hours

3.1 Tacheometry

Scope – System of Tacheometry – Stadia and Tangential systems – Principles –Tacheometric Constants -Fixed hair method – Analatic lens (no proof) - Advantages and use – Distance and elevation formulae –Simple problems – Distomats (Description only) Direct Reading Tacheometers– Tacheometric Traverse – Errors in Tacheometric work – problems.

3.2 Total Station

Introduction – Accessories with description - Features of total station – Onboard software electronic data reading - Summary of total stations characteristics - Field procedure of total stations in topographic survey.

UNIT-4

20 Hours

4.1 Areas & Volumes

Computation of areas of irregular figure – Trapezoidal rule - Simpson's rule -Problems
Volume of irregular solids- Trapezoidal rule - Prismoidal rule –Problems on embankment and cuttings – cross sectional areas -level section – two level sections only – simple problems.

4.2 Contour Surveying

Definition –Contour - Contouring - Characteristics of Contours - Methods of Contouring – Direct and Indirect methods – Interpolation of Contour – Contour Gradient – Uses of Contour plan and Map– Calculation of capacity of reservoirs -Simple problems.

4.3 Curves

Types of Curves - Designation of curves –Elements of Simple Curve- Setting out simple circular curves-Linear methods(Description only)–Methods of setting out Curve by Rankine's method of deflection angles – Simple Problems.

UNIT- 5

20 Hours

MODERN SURVEYING

5.1 Global position system (GPS)

Introduction-Variou satellite used by GPS-Differential GPS-Fundamental importance – Receivers – Observation and data processing application in Civil Engineering.

5.2 Geographical Information System (GIS)

MAP – Types of Maps – Development of GIS – Components of GIS – Ordinary mapping to GIS – Comparison of GIS with CAD and other system – Fields of Applications – Natural Resources – Agriculture – Soil – Water Resources – Wasteland Management - Social Resources - Cadastral Records – LIS.

Note: All Exercises for GIS and GPS are available in CD - Learning Material Development Project at NITTTR (TTI), Taramani, Chennai

Test & Revisions

12 Hours

Reference Books :

1. Kanetkar.T.P. & S.V.Kulkarni, "Surveying and levelling part I & II ", Puna vidyarthi girha, Prakashan,23rd edition,1993.
2. Punmia.B.C., "Surveying Volume-1 & Volume-2", "Laxmi Publications(p)Ltd., 13th edition, 2002.
3. Punmia.B.C., "Surveying & Field work part I & II ",Laxmi Publications(p)Ltd., 13th edition, 2002.
4. Agor.,"A Text Book of Surveying Levelling ", Khanna publishers ,6th Edition 1984.
5. Duggal .S.K.,"Surveying volume I & II ",Tata Mc Graw hill newdelhi,1996,1st Edition
6. Rangwala.S.C.,"Surveying & Levelling",Charotar Publishing House,3rd Edition,1991.
7. Sathesh Gopi, R.Sathikumar & N.Madhu, Advanced Surveying,(Total Station, GIS, Remote sensing),Pearson Education, Chennai, 2007.
8. Burrough P A, Principles of GIS for Land Resources Assessment, Oxford Publication, 2000.
9. Michael N Demers, Fundamentals of Geographical Information Systems, Second Edition, John Wiley Publications, 2002
- 10.Paul A Longley, Michael F Goodchild etal, Geographical Information Systems Volume I and II, Second Edition, John Wiley Publications, 1999.
11. Learning Material Development Project – NITTTR(TTI),Taramani,Chennai, CD programme for Exercises for GPS and GIS.

* * *

11034 - CIVIL ENGINEERING DRAWING - I

6 Hours/Week

16 Weeks

96 Hours

OBJECTIVES:

- Able to do effective planning.
- Prepare layout of buildings.
- Gain thorough knowledge of the rules, regulations and standards of buildings.
- Able to Read the line sketch and prepare plan, sections and elevations of buildings.

1. INTRODUCTION

6 Hours

Terms used in drawing as per NBC– Open space requirements as per NBC – Building requirements – Minimum dimensions as per NBC – FAR and Floor space Index(FSI) for different buildings and zones – Function of local authority-Municipal bye-Law – List of documents to be submitted for building plan approval.

Drawing instruments and their uses – Scales – Selection of Scales – French curves – Scanners and Plotters – Abbreviations used in Civil Engineering Drawing.

II PLANNING

12 Hours

Principle of Planning-Orientation-Planning of residential building – Factors to be considered in Planning – Minimum size requirements of Living, Bed room, Kitchen & Toilet in a Residential Building –Standard sizes of Door, Windows and ventilators- Planning of rooms - Preparation of line sketch for a single bed room residential building of 50 m² Plinth area- Preparation of line sketch for a double bed room residential building of 75 m² Plinth area – Site plan – Layout plan-Key plan –(preparation of Line sketch is not for Examination. It is only for practice, Staff members are advised to give more exercises for better practice).

III DRAFTING AND DETAILING

12 Hours

1. Standard symbols used in Civil Engineering Drawing
2. Elevation of
 - a) Flush Door
 - b) Steel Roof Truss
3. Prepare the Plan for the following, including location of furniture's, fixtures and futures in each category.(nominal sizes)
 - a) Living Room
 - b) Bed Room
 - c) Kitchen
 - d) Toilet
4. Rain Water Harvesting Methods – Prepare Plan and section of
 - a) Shallow Well method
 - b) Percolation Pit method

IV BUILDING DRAWINGS

54 Hours

Preparation of Plan, Section and Elevation of buildings with specification for the given line drawing using suitable scale: -

1. A Residential building with single bed room and attached bathroom.(R.C.C. flat roof)
2. A residential building with two bed rooms(R.C.C Flat Roof)
3. A single roomed house with fully tiled roof with gable ends.
4. Single storied Residential Building- Hall/Living-two beds with attached Toilet and Common stair case.
5. Library building with R.C.C. flat roof.
6. A Restaurant building in R.C.C. flat roof.
7. Single storied school building with R.C.C. flat roof.
8. Small workshop with north light steel roof truss up to 10m span over R.C.C. Columns.
9. Hospital Building of 300 m² Plinth area.
10. A Prayer/Meditation Hall with tubular Truss and Metal Sheet Roofing.

Note: All the Drawing should contain Title Block, Specifications and other details as per in practice.

Revision & Test

12 hours

Scheme of Examination

Part A	-(From I & II -1 X 3 , From III -1 X 12) -	15 Marks
Part B	- (From IV)	- 60 Marks
Total External		75 Marks
Internal Assessment		25 Marks
Total		100 Marks

Reference Books:

1. National Building Code
2. TamilNadu District Municipal building rules and by-laws
3. B.P. Verma ,”Civil Engineering Drawing and house planning”
4. Dr. N. Kumaraswamy and A. Kameswara Rao,” Building Planning and Drawing”,
5. G. Vaidhyanathan, I. Kulasekaran, G. sathish Kumar “Building Planning and Construction Companion”, .
6. S.C.Rangwala ,”Civil Engineering Drawing “,
7. V.R.Thothathri, “A Guide to Civil Engg Drawing

11035-MATERIAL TESTING LAB PRACTICE - I

3 Hours / Week

16 Weeks

48 Hours

OBJECTIVES:

- Study of UTM, Torsion testing machine, Hardness tester, Compression testing machine.
 - To determine the Material Properties- test conducted on steel, wood, cement, aluminium, Brass and Brick.
1. Study of UTM, Torsion testing machine, Hardness testing Machine, Compression testing Machine etc.

Part – A

18 Hours

1. Tension test on M.S. bars (Round, Square, Rectangular cross section)
2. Deflection test on steel beam
3. Deflection test on wooden beam
4. Consistency test on cement
5. Initial / final setting time of cement
6. Torsion test on M.S. bar

Part – B

18 Hours

1. Double shear test on M.S. bar
2. Rock well / Brinell's Hardness test on M.S, Aluminium & Brass
3. Compression test on Wooden cube.
4. Impact Test on M.S. Specimen
5. Fineness test on Cement
6. Compression test on Bricks
7. Water absorption test on Bricks
8. Determination of flexural strength of Tiles

In the examination the students have to be given two experiments one in Part - A (40 Marks) and one in Part – B (30 Marks).

Part-C

6 Hours

1. Collection of Building Materials and Prepare Report on Specifications, Properties, Cost, and Resources of each Material. (5-Marks awarded in Internal Marks of 25)

Revision & Test

6 Hours

* * *

11036- SURVEYING PRACTICE - I

6 Hours / Week

16 Weeks

96 Hours

Objectives:

- Laying of chain and Exercise on chain survey.
- Study on compass and Exercise on compass survey.
- Study on Levelling Instrument and Exercise on Levelling.
- Selection of Routing using GPS
- Reading of various maps

PART- A

1. Chain Survey

15 Hours

- 1.1 Chaining and ranging a line.
- 1.2 Chaining and taking offsets
- 1.3 Determination of area of a plot.(Minimum two Exercises)
(One chain line and at least two offsets on either side of chain line)

2. Compass Survey

15 Hours

- 2.1 Setting up Prismatic compass over a station and observing bearing of a line
- 2.2 Closed traverse and finding the included angles – Minimum 5 Points and Two Exercises.

PART- B

42 Hours

3. Levelling

- 3.1 Temporary adjustment of Dumpy level taking readings and booking
- 3.2 Fly levelling – Reduction by Height of Collimation – Minimum 6 Points with two change points (Minimum Four Exercises)
- 3.3 Fly levelling – Reduction by Rise and fall – Minimum 6 Points with two change points. (Minimum Four Exercises)
- 3.4 Check levelling and reduction of levels (Minimum Four Exercises)
 - a. By Height of Collimation Method
 - b. By Rise and fall Method.

PART- C

12 Hours

4.0 GPS

- 4.1 Reading of various map like
 - a. District Map
 - b. Taluk Map
- 4.2 Study of handled **GPS**
- 4.3 Measurement of latitude and longitude using handled **GPS**
- 4.4 Selection of routing (Points) using handled **GPS**

Note: All Exercises are available in CD - Learning Material Development Project at NITTTR (TTI), Taramani, Chennai – 113.

In Examination questions will be chosen are as follows:

	PART- A	
By lot ONE question (Either in chain survey or compass survey)	- 25	Marks

	PART- B	
Levelling Compulsory	- 35	Marks

	PART- C	
ONE question from GPS	- 10	Marks
Viva-Voce	- 5	Marks
Record	- 25	Marks

	TOTAL	
	-100	Marks

* * *

11031-ENGINEERING MECHANICS

MODEL QUESTION PAPER - I

TIME : 3 HRS

MAX.MARKS : 75

- Note :**
- 1 Answer ALL QUESTIONS from **PART - A** each carrying 1Mark
 - 2 Answer ALL QUESTIONS from **PART - B** each carrying 3Marks
 - 3 Answer ALL QUESTIONS from **PART –C** choosing either a or b each carrying 10 Marks

PART A (10 X 1 = 10)

1. Write the expression for elongation of a prismatic bar due to self weight.
2. Define Poisson's ratio?
3. Draw the sketch of the fixed support specifying the reaction components.
4. What is the bending moment at Support for the cantilever beam carrying point load at free end?
5. Define Centroid?
6. State the formula for polar moment of Inertia of Hollow circular column section.
7. Write the Equation of Bending.
8. Write the Torsional Equation
9. Define Perfect frame
10. What is couple?

PART B (5 X 3 = 15)

11. Explain the properties, brittleness and ductility.
12. Define statically determinate beam. Give two examples.
13. Define radius of gyration. State the formula for rectangular section.
14. Differentiate between flexural rigidity and torsional rigidity.
15. Explain space diagram and vector diagram.

PART C (5 X 10 = 50)

16. (a) 1. Explain different types of stresses.
2. A brass rod 20mm diameter and 15m long is subjected to an axial pull of 40 KN. Find the stress, strain and elongation of the bar, if the modulus of the elasticity of the bar is 1×10^6 N/mm².
(b) A steel flat 150mm wide 20mm thick and 6000mm long carries a pull of 300 KN. Find the extension in length and contraction in width and thickness under the pull. Take the Poisson's ratio as 0.3 and $E = 2 \times 10^5$ N/mm². Calculate also the change in volume.
17. (a) 1. What do you understand by the term point of contra flexure? Explain with Neat sketch.
2. A cantilever of 4m span carries a point load of 8 KN at the free end and an UDL of 3 KN/m over the half of the beam from the flexed end. Construct SFD and BMD.
(b) 1. Draw the SF and BM diagram of the beam shown in the fig.1. State the values of maximum hogging and sagging moments and their location.
18. (a) 1. State and prove the perpendicular axis theorem.
2. Find the center of gravity of an inverted T- section with flange 60 x 10 mm and web 50 x 10 mm.
(b) 1. Find the moment of inertia of the channel section shown in the fig.2. about horizontal and vertical centroidal axes.

19. (a) 1. A cantilever of span 1.5m carries a point load of 5KN at the free end. Find the modulus of section required, if the bending stress is to exceed 150N/mm^2 .
 2. Derive the formula for power transmitted by the shaft.
- (b) 1. A solid circular shaft has to transmit a power of 40 KW at 120 rpm. The permissible shear stress is 100 N/mm^2 . Determine the diameter of the shaft, if the maximum torque exceeds the mean torque by 25%
20. (a) 1. Using analytical method, find the forces in all the members of the truss shown in the fig.3.
- (b) 1. Using graphical method, find forces in all the members of the truss shown in fig.4.

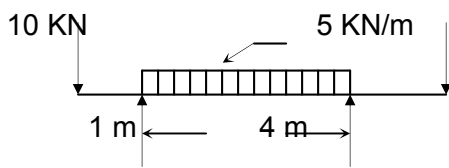

Fig. (1)

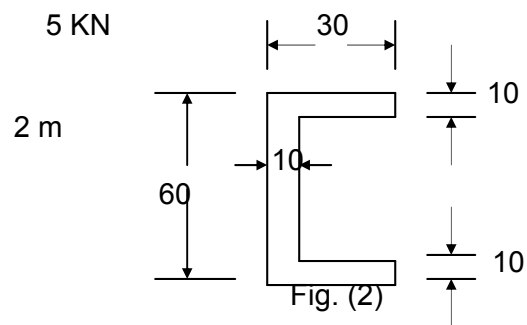

Fig. (2)

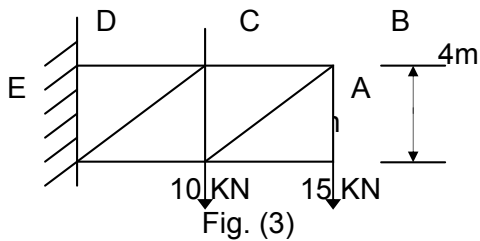

Fig. (3)

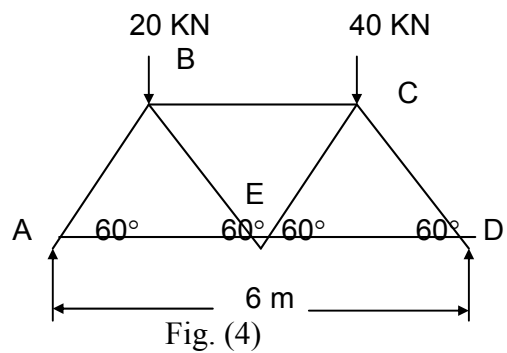

Fig. (4)

11031-ENGINEERING MECHANICS

MODEL QUESTION PAPER - II

TIME : 3 HRS

MAX.MARKS : 75

- Note :** 1 Answer ALL QUESTIONS from **PART - A** each carrying 1Mark
2 Answer ALL QUESTIONS from **PART - B** each carrying 3Marks
3 Answer ALL QUESTIONS from **PART –C** choosing either a or b each carrying 10 Marks

PART A (10 x 1= 10)

1. Write the equations for bulk modulus and rigid modulus.
2. Define Creep and Fatigue
3. Draw the shear force diagram for the cantilever beam with point load at free end.
4. Define Bending moment diagram
5. Write the position of centroid of a rectangle whose breadth is 'b' and depth is 'd'.
6. Define section modulus
7. Define Theory of Simple Bending.
8. Define Torsional Rigidity.
9. Write the expression for the imperfect frame.
10. What is resolution of forces?

PART B (5 x 3= 15)

11. Write the expression related with modulus of rigidity (μ), bulk modulus (k) and Poisson's ratio (ν).
12. What is point of contraflexure? Differentiate cantilever and simply supported beam.
13. State perpendicular axis theorem and parallel axis theorem.
14. Derive the section modulus for rectangular section.
15. Write any four assumptions made while analyzing the framed structures.

PART C(5 x10 = 50)

16. (a) 1. State (i) Hook's law (ii) Elastic limit (iii) Elasticity
2. An alloy wire of 2.5mm^2 cross sectional area and 14n weight hangs freely under its own weight. Find the maximum length of the wire, if its extension is not to exceed 0.7mm . Young's modulus of material is 160Gpa .
Or
(b) 1. During tension test on M.S. specimen the following observations were made. Diameter of the rod 25mm , gauge length 250mm , Yield and ultimate loads and breaking loads are 90 KN , 125 KN and 100 KN respectively. The final length of the specimen is 256.6mm and Neck diameter is 19.5mm . Determine Yield stress, Breaking stress, Ultimate stress, % elongation and contraction.
17. (a) 1. Sketch the different types of beam according to support condition and State anyone example for each beam.
2. Draw BMD and SFD for the cantilever beam of 3m , which carries UDL of 10 KN/m for 1m from fixed end and concentrated load of 20 KN at the free end.
Or
(b) 1. Sketch SF and BM diagram for the beam shown in figure(1).

18. (a) 1. Sketch any three unsymmetrical sections and show their centroidal position
2. Calculate the moment of inertia of a hollow circular section whose external diameter is 4m and thickness is 300mm.
- Or
- (b) 1. Determine the position of neutral axis and moment of inertia about neutral axis for the section shown in fig(2). Also find the section modulus and radius of gyration about both axes.
19. (a) 1. Sketch the shear stress diagram for beams of various cross section.
2. A wooden beam of rectangular section 200 x 400mm is simply supported over a span of 8m. What UDL it may carry if the maximum bending stress does not exceed 7.5N/mm^2 . For what maximum span this beam could be provided to carry a UDL OF 6KN/M.
- Or
- (b) 1. A bar of 30mm diameter was tested in a gauge length of 300mm in tension and torsion. A tensile load of 60kN produced an extension of 0.5mm and a torque of 0.20 KNm produced a twist of 1.62° . Determine (i) Young's modulus (ii) Modulus of rigidity (iii) Bulk modulus (iv) Poisson's ratio.
20. (a) 1. Explain classification of frames with examples.
2. Determine the magnitude and nature of forces in the members AB and AC. as shown in fig.(3).
- Or
- (b) 1. Determine the forces in the members of the truss shown in the fig.4 Using graphical method or analytical method.

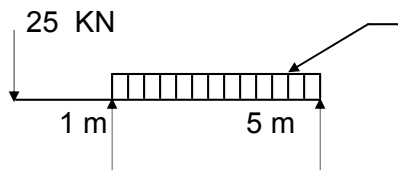

Fig. (1)

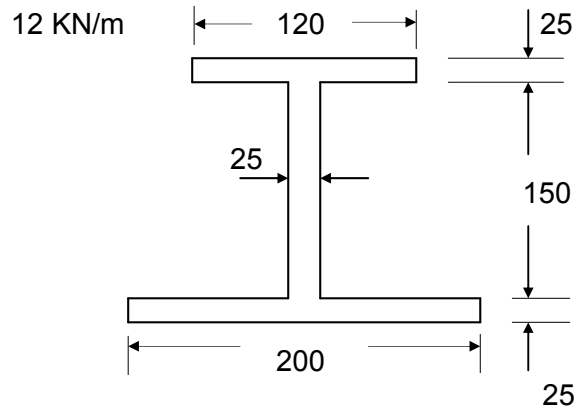

Fig. (2)

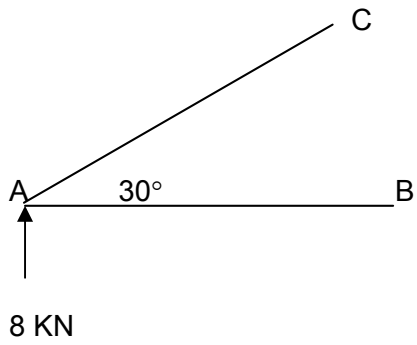
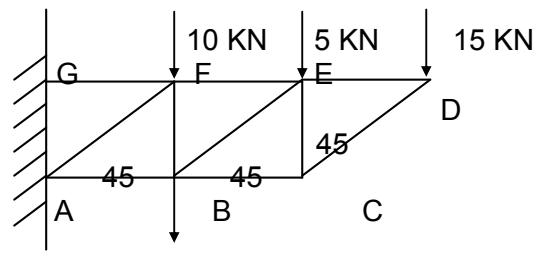

Fig. (3)



10 KN
Fig. (4)

11032 – CONSTRUCTION MATERIALS AND PRACTICE

MODEL QUESTION PAPER – I

TIME : 3 HRS

MAX.MARKS : 75

- Note :** 1 Answer ALL QUESTIONS from **PART - A** each carrying 1Mark
2 Answer ALL QUESTIONS from **PART - B** each carrying 3Marks
3 Answer ALL QUESTIONS from **PART –C** choosing either a or b each carrying 10 Marks

PART A (10 x 1 = 10)

1. What are the classification of rocks?
2. What are the sources of Lime?
3. Define workability of concrete.
4. What are the classification of Glass?
5. Define sill.
6. What are the materials used for Damp proofing
7. Why weathering course is laid in the top of roof slab?
8. Name the Horizontal upper portion and vertical portion of a step.
9. Define pointing.
10. Write down the different material used for outside white washing?

PART B (5 x 3 = 15)

11. What are the constituents of good brick earth?
12. What are the properties of good Mortar?
13. State the Objectives of foundation.
14. What you mean by Shell roof and where it is used.
15. Draw a neat sketch of Single Scaffolding.

PART C (5 x 10 = 50)

16. a) What are the various stages in the manufacture of brick and Explain them Briefly.
Or
b) What are the varieties of cement? When they are used?
17. a) Explain the methods of preparation of concrete.
Or
b) Describe in details various types of defects of painting.
18. a) What are the different types of Shallow foundation and explain any two.
Or
b) Explain the Construction details of an English bond with neat sketches (one brick)
19. a) Where will you locate doors in building and draw neat sketch of fully paneled door& name in parts
Or.
b) List out the various types of floors and explain any two.
20. a) i Explain the process of plastering in cement mortar with two coats.
ii. Explain the process involved in colour washing.
Or
b) i Explain the process of preparation and methods for white washing
ii. Draw the form work for slab and explain the precaution to be taken.

* * *

11033 –SURVEYING

MODEL QUESTION PAPER - I

Time: 3 Hours

Max. Marks: 75

- Note :** 1 Answer ALL QUESTIONS from **PART - A** each carrying 1Mark
2 Answer ALL QUESTIONS from **PART - B** each carrying 3Marks
3 Answer ALL QUESTIONS from **PART –C** choosing either a or b each carrying 10 Marks

PART A (10x13 = 10)

- 1.What are the principles of surveying?
2. What are the types of levels?
- 3.What are the types of Theodolite?
4. List out the fundamental lines of a Theodolite
5. Any two advantages and disadvantages of tangential tachometry.
6. What is Total Station?
- 7.Write down the simpson’s Formula for computing areas.
8. Define contour map.
9. Expand GIS.
10. Expand GPS.

PART- B

11. Define magnetic meridian, True Meridian.
12. Derive the formula for single plane method in trigonometrical leveling for any one case.
13. How to find out Tacheometric Constant in the field?
14. Define the Characteristics of Contour.
15. State features of ‘GIS’.

PART- C (5 x 10 = 50)

- 16.a.The bearing of the sides of a traverse ABCDE as follows:

Side	FB	BB
AB	103°15'	283°15'
BC	18°00'	198°00'
CD	277°30'	97°30'
DE	185°15'	5°15'
EA	120°45'	300°45'

Compute the interior angles of the traverse.

(or)

- b. The following consecutive readings were taken with a dumpy level and a 4m levelling staff on continuously sloping ground at a common interval of 30m 0.585 on A 0.936, 1.953, 2.846, 3.644, 3.938, 0.962, 1.035, 1.689, 2.534, 3.844, 0.956,

1.579, 3.016 on B. The elevation of A was 520.450, make up a level book and apply the usual checks. Determine the gradient of the line AB.

17. a. The following Length and bearing were received in running a Theodolite traverse ABCDE. There are obstacles which prevent direct measurement calculate the length of DE and bearing of EA.

Line	Length in meters	Bearing
AB	485	314°48'
BC	1725	16°24'
CD	1050	142°06'
DE	?	220°12'
EA	920	?

(or)

- b. The following observation refers to a past of traverse survey.

Line	Length(m)	Bearing
AB	160	20°15'
BC	365	130°15'
CD	480	220°25'

Find the distance between a point P on AB 90 m from a point Q 225 m from C.

18. a. Find the mean value of the multiplying, constant of a tacheometer with the following observations.

Observation	Horizontal Distance (m)	Vertical angle	Staff readings
1	60	0°0'	0.955, 1.545
2	120	1°15'	1.260, 2.465
3	180	1°40'	1.360, 3.110

(or)

- b i. Derive the principle of stadia and deduce the formula for horizontal Distance.
 ii. Explain the Field procedure of total stations in topographic survey.
19. a. The areas within the contour lines at the site of the reservoir and the face of the proposed dam are as follows:

contour	Area in mm ²
101	1000
102	12800
103	95200
104	147600
105	872500
106	1350000
107	1985000
108	2286000
109	2512000

Taking 101 as the bottom level and 109 as the top level of the reservoir calculate the capacity of reservoir by prismoidal formula.

(or)

- b. Two straights intersect at chainage 1615m, the deflection angle being 11° . Calculate all the data necessary to set out a 3° simple right handed curve by the Rankine's methods of deflection angles peg interval may be taken on 20m. Draw the table of deflection angle.

20. a.) i. Explain the mapping by GPS.
 ii. What are the types of MAP used in GPS
 (or)
 b) i. Explain GPS
 ii. What are the field application of GIS

* * *

11033 - SURVEYING

MODEL QUESTION PAPER - II

Time: 3 Hours

Max. Marks: 75

- Note :** 1 Answer ALL QUESTIONS from **PART - A** each carrying 1Mark
2 Answer ALL QUESTIONS from **PART - B** each carrying 3Marks
3 Answer ALL QUESTIONS from **PART –C** choosing either a or b each carrying 10 Marks

PART A (10 x 1 =10)

1. Define surveying.
2. What do you mean by 'Local Attraction'?
3. Define latitude and departure.
4. Draw the plan of Double plane method marking Instrument station and object station.
5. Define Tacheometer
6. Define Distomat
7. Write down the Trapezoidal formula for irregular areas.
8. What is meant by contour gradient?
9. Define GPS Receivers
10. How the GIS is used in Agriculture

PART B (5 x 3 = 15)

11. Define the Division of Surveying.
12. Explain the Temporary adjustments made in the theodolite setting.
13. Write down the distance and elevation formula for elevated point using stadia Tacheometer
14. Explain the methods of setting out the curve by Rankines method of deflection angle.
15. List the fundamental operation of GIS.

PART- C (5 x 10 = 50)

16. a The following were the bearing observed from two stations R and S, 80 meters apart for two inaccessible points P and Q find the distance PQ.

Line	Bearing
RP	340°
RQ	30°
RS	80°
SR	260°
SP	320°
SQ	2°

(or)

b. The following staff readings were taken with dumpy level

3.185,3.845,2.165,2.645,2.780,0.985,2.645,0.430,1.465,1.570,0.790,1.945,0.650, 1.340,0.530. The level was shifted after the fourth, eighth and twelfth reading.

The first reading was taken on a B.M of RL.100.00 enter the staff reading in a level book form and reduce the level of all the points by rise and fall method. Apply the using check.

17. a. The following Length and bearing were received in running a theodolite traverse ABCD. There are obstacles, which prevent direct measurement of bearing and length of line AD. Calculate length and bearing of AD.

Line	Length in meters	Bearing
AB	485	314°48'
BC	1725	16°24'
CD	1050	142°06'

(or)

b Find the elevation of the top of chimney from the following data.

Instrument station	Reading on BM	Angle of elevation	Remarks
A	0.865	18°36'	RL of BM=320.35m
B	1.225	10°12'	Distance AB=50m

Station A, B and the top of the chimney is in the same vertical plane.

18. a. A tachometer is set up at an intermediate points on a traverse course AB and the following observations are made on a vertically held staff.

Staff Station	Intercept	Axial hair reading	Bearing	Vertical Angle
A	2.225	2.015	218°37'	-5°30'
B	2.050	1.220	38°37'	-6°20'

The instrument is fixed with an anallatic lens and the constant is 100. compute the length of AB and RL of A is 226.800m

(or)

- b i. Derive the Formula for Tangential system of Tacheometer for elevated point
 - ii. Explain the advantages of Total Station.
19. a. The area enclosed by contours at the site of a reservoir and the face of the proposed dam as computed by a planimeter are as shown below.

Contour level (m)	Area (sq.m)
1000	400
1005	1500
1010	3000
1015	8000
1020	18000
1025	25000
1030	40000

Taking 1000m as the bottom level of the reservoir and 1030m highest level achievable, compute the capacity of the reservoir by trapezoidal formula and prismoidal formula

(or)

- b. Two straights intersect at chainage 1615m, the deflection angle being 11° . Calculate all the data necessary to set out a 3° simple right handed curve By the Rankine's methods of deflection angles peg interval may be taken on 20m. Draw the table of deflection angle.

20. a i. Briefly explain the application of GIS in i. Forestry, ii. Hydrology, iii. Geology
- ii. What are the fundamental importance of GPS
- (or)
- b i. Explain the fundamental importance of GPS
 - ii. How the records are maintained in GIS.

* * *

11034-CIVIL ENGINEERING DRAWING

MODEL QUESTION PAPER - I

- N.B.
1. Answer all questions under Part A in the answer book supplied.
 2. Answer question under Part B in the drawing sheet supplied.
 3. The sketches under Part A should be drawn using pencil and drawing instruments, not necessarily to scale.
 4. Any data, not given may be assumed suitable and should be indicated in the drawing.

PART – A

I. Answer the following (1 x 3 = 3)

1. What is the main factor to be considered while planning?
2. Specify the minimum dimension of a living room in residential building as per the NBC standards.
3. What is the minimum plot area required for a residential building as per Municipal bye laws?

II Sketch the elevation of a steel truss using the following details (1 x 12 = 12)

Wall thickness	: 300 mm
Bottom tie member	: 2 Nos flat 80 X 6 mm
Pitch of roof	: 30°
Strut	: Single ISA 70 X45 X 8 mm
Principal rafter	: Two ISA 80 X 50 X 8 mm
Cleat angle	: 75 X 75 X 8 mm
Purlins	: 125 X75 X 8 mm
All other ties	: 60 mm X 10 mm flat
Roof covering	: G.I. Sheet
Gusset Plate	: 10 mm thick

PART B

III The sketch shows the line plan of “A two bed room house with R.C.C. roof”. The dimensions noted therein indicate the clear dimensions between the inside walls. The specifications are given below:-

Foundation:-

Foundation shall be of C.C. 1:4:8 mix, 1000 wide and 300 thick laid at 1100 below G.L. for all main walls and verandah retaining wall. It consists of two footings of size 700 X 400 and 500 X 400 in C.M. 1:6.

Basement:-

The basement will be in brick work in C.M. 1:5, 300 mm wide and 600 thick above G.L. A Damp Proof course in C. M. 1:3, 20 thick will be provided for all walls.

Super Structure:-

All main walls will be in brick work in C.M. 1:5, 200 mm thick. The inner partition walls in toilet will be 100 mm thick. The height of all the walls will be 3000 mm above floor level.

Roofing:-

The roofing will be R.C.C. 1:2:4 mix, 120 mm thick flat slab. Verandah slab will be of R.C.C. 1:2:4 mix, 100 thick at a height of 2600 mm from verandah floor level. A weathering course in brick jelly lime concrete plastered with mortar 1:5:9 mix, 75 mm thick will be provided.

Lintels:-

R.C.C. lintel 120 thick over all the openings shall be provided. Suitable sunshades for all external openings shall be provided.

Flooring:-

The flooring will be in C.C. 1:4:8, 120 mm thick plastered smooth with C.M. 1:3, 20 mm thick for all the portions.

Steps:-

Provide steps of rise 150mm and tread 250 mm

Draw the following views to a suitable scale:-

- a) Plan of the building 20 Marks
- b) Section on "AB" 25 Marks
- c) Front Elevation 15 Marks

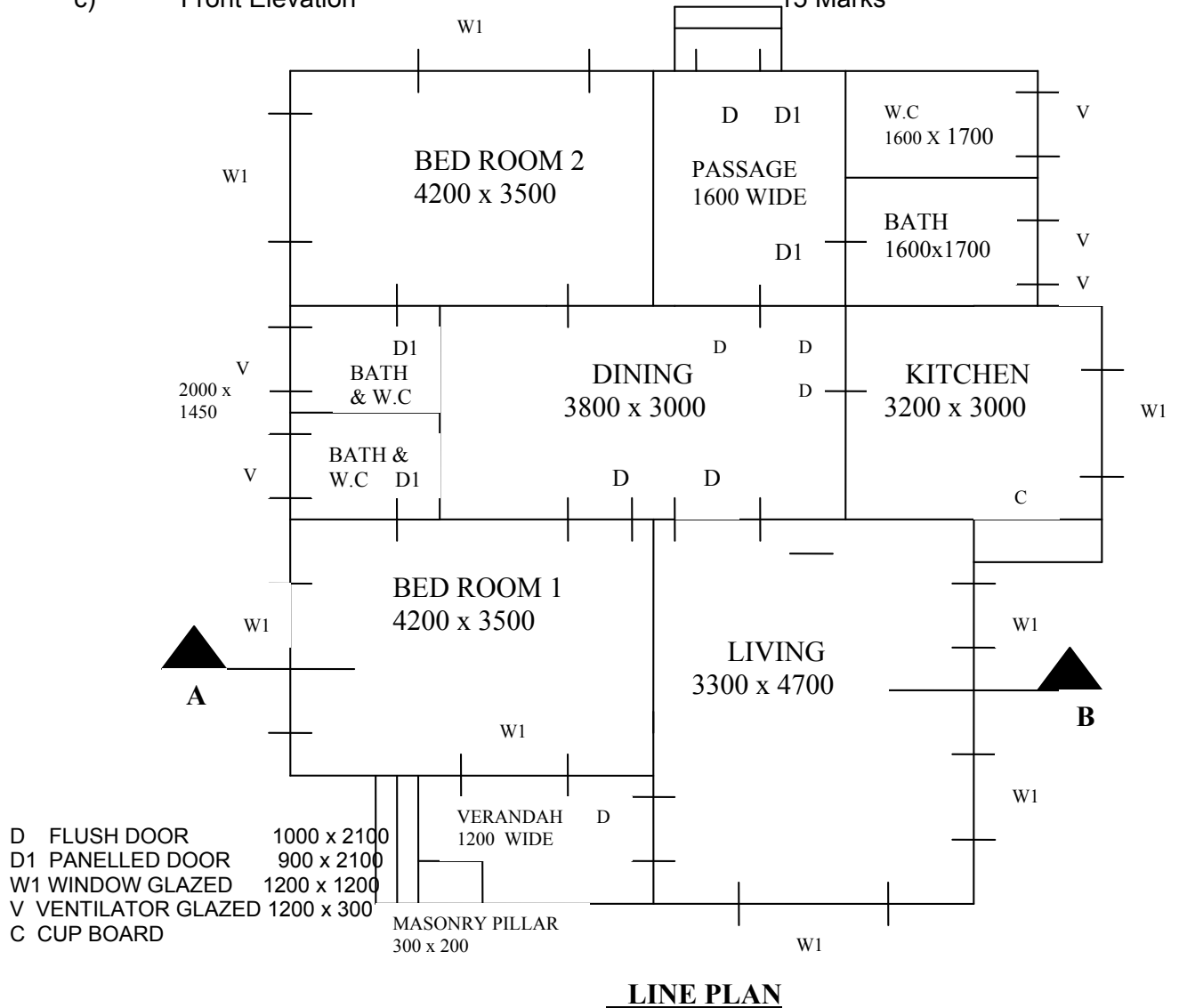

11034-CIVIL ENGINEERING DRAWING – I

MODEL QUESTION PAPER - II

- N.B.
1. Answer all questions under Part A in the answer book supplied.
 - 2 Answer question under Part B in the drawing sheet supplied.
 - 3 The sketches under Part A should be drawn using pencil and drawing instruments, not necessarily to scale.
 - 4 Any data, not given may be assumed suitable and should be indicated in the drawing.

PART – A

- I. Answer the following (1 X 5 = 5)
- 1 Draw the conventional sign for Stone and timber in cross-section
 - 2 Specify the minimum dimension of a kitchen in residential building as per the NBC standards.
 - 3 Explain ventilation of buildings?
 - 4 Define Floor Area ratio.
 - 5 Mention the scales used for preparing the site plan and building plan.
- II Sketch the elevation of a flush door of size 1200 X 2100. Assume any other data necessary. (1 x 10 = 10)

PART-B

- III The following specifications correspond to the line plan of a “work shop building with steel roof truss” The dimensions noted in the sketch indicate the clear dimensions between the inside walls.

Foundation: The foundation for all main walls will be in cement concrete 1:5:10 mix, 900x200 thick, laid at 600 below ground level. The masonry footing will be in brick work in cement mortar 1:5.500 wide and 400 thick for all walls

Basement: The basement will be in brickwork in cement mortar 1:5, 400x450 above ground level for all walls and is filled with earth, 300 thick.

Superstructure: All the pillars, 300x300 and 4000 high. At 3000 C/C will be in brick work in cement mortar 1:5, for 4000 high. All the walls and the pillars including the basement will be plastered smooth with cement mortar 1:4 externally and 1:5 internally for 12.5 thick.

Roofing: The roofing will be of asbestos cement sheet laid on steel truss as designed. The trusses will be spaced at 3000 center to centre. They are 5 bays. Eaves projections will be 600 beyond the outer face of walls.

Doors, windows etc.,

RS	-Rolling shutter	: 3000x2400
D1	-Steel door	: 1000x2000
D2	- Steel door	: 800x2000
W1	-fixed glazed peeping window:	1500x1200
W2	-Glazed window	: 1000x1200
V	-Glazed ventilator	: 1000x500

Lintel: All external wall openings will be provided with R.C.C 1:1:5:3 mix, lintel- cum-sunshade, 150 thick and 600 wide. All internal wall openings will be provided with 150 thick R.C.C. 1:1:5:3: mix lintels.

Flooring: The flooring will be in cement 1:3:6 mix, 130 thick, and the top plastered smooth with cement mortar 1:3, 20 thick.

Steps: Steps will be in brick work in cement mortar 1:5 mix, laid on 800x3700, 150 thick cement concrete 1:5:10 mix footing. Rise=150. Tread=300. Ramp in cement concrete 1:4:8,3000x2000 will be provided.

The accommodation consists of the following:

- i. Manager room : 2800x2800
- ii. Office : 2800x4300
- iii Toilets :2800x1800
- iv Verandah :1800 wide
- v. Workshop : 17800X9500

Draw to a suitable scale, the following views with complete dimensions and details.

1. Plan at window sill level 20 Marks
2. Sectional elevation on 'AB' 25 Marks
3. Front elevation. 15 Marks

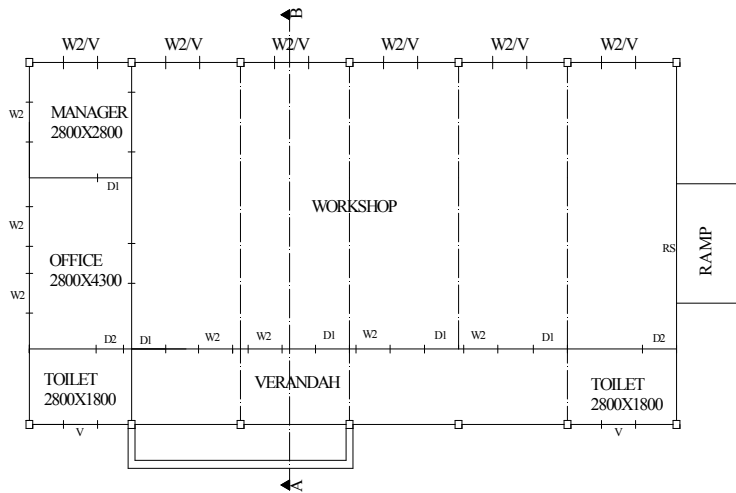

REFERENCE		
TYPE	DESCRIPTION	SIZE
RS	ROLLING SHUTTER	3000X2400
D1	STEEL DOOR	1000X2000
D2	STEEL DOOR	800X2000
W1	FIXED GLAZED WINDOW	1500X1200
W2	GLAZED WINDOW	1000X1200
V	VENTILATOR	1000X500
<u>STEPS</u>		
	RISE	150
	TREAD	300

IV-SEMESTER

11041 -THEORY OF STRUCTURES

7 Hours / Week

16 Weeks

112 Hours

Objectives:

- Determine the Slope and Deflection of Determinate beams by area moment method.
- Analysis of propped cantilever & fixed beam and draw SFD, BMD.
- Define type of arches and analyse three hinged arch.
- Analyse Continuous beam by Theorem of Three moment and draw SFD, BMD.
- Analyse continuous beams and portal frame by Moment Distribution Method and draw SFD, BMD.
- Define different types of columns and to find critical load of columns.
- Analyse of columns and chimneys subject to eccentric loading and to find maximum, minimum stresses.
- Calculation of maximum, minimum stresses & checking stability of Masonry Dams and Retaining walls.
- Solving problems in the course of study.

UNIT – 1

20 Hours

1.1 Slope and Deflection of beams

Understanding concept of Roller, Hinged and Fixed Supports- Analysis of supports - Deflected shapes of beams with different support conditions – Flexural rigidity and stiffness of beams- Derivation of differential equation of flexure – Area Moment method – Mohr's theorem for slope and deflection of beams – Derivation of expressions for maximum slope and maximum deflection of simple standard cases by area moment method for cantilever and simply supported beams subjected to symmetrical UDL & point loads – Numerical problems on slope & deflections at salient points from first principles – simple problems.

1.2 Propped cantilevers

Understanding concept of Beam action and Beam analysis- cantilever-simply supported- Definition of Prop – Statically indeterminacy – Prop reaction from deflection consideration – SF & BM diagrams by area moment method for UDL throughout span, central and non-central concentrated loads.

Unit – 2

20 Hours

2.1 Fixed beams

Introduction to fixed beam – sagging & hogging bending moments – Determination of fixing moments by area moment method – standard cases – Fixed beams subjected to symmetrical & unsymmetrical concentrated loads and UDL – SF & BM diagrams for supports at the same level (sinking of supports at different levels not included) – slope and deflection of fixed beams subjected to UDL & concentrated loads (symmetrical loads only) by area moment method only – Problems.

2.2 Arches

Understanding concept of an Arch- Comparison of Arch and Beam Action-Eddy's theorem (no proof required) Line or resistance – Actual & theoretical arches – Different types of

arches – 3 hinged arches – segmental & parabolic arches – problems with simple symmetrical loading only.

UNIT – 3

20 Hours

3.1 Continuous beams – Theorem of three moments

Introduction – Definition of Indeterminate structures – General methods of analysis of Indeterminate structures – Clapeyron's theorem of three moments - statement – Application of Clapeyron's theorem of three moments for the following cases – Problems on two span – simply supported ends – one end fixed and the other simply supported – simply supported with one end overhanging – Propped cantilever – sketching of SFD & BMD for the above cases.

3.2 Continuous beams – Moment distribution method

Introduction – sign conventions – stiffness factor – carry over factor – Distribution factor – Application to continuous beams upto three spans & propped cantilever – Problems – Portal frames symmetrical frames only (no sway correction) – sketching BMD only for beams and frames.

UNIT – 4

20 Hours

4.1 Columns and struts :

Columns and struts – Definition – short and long columns – End conditions – equivalent length – Slenderness ratio – Axially loaded short column - Axially loaded long column – Euler's theory of long columns – derivation for hinged end conditions – other standard cases of end conditions (separate derivations not required) – problems – Rankine's formula – derivation – simple problems.

4.2 Combined bending and direct stresses :

Introduction – Eccentric loading – Effects of eccentric loading on structures in general and short columns in particular – combined direct and bending stresses – maximum and minimum stresses – problems – conditions for no tension – Limit of eccentricity – Middle third rule – core or kern of sections for square, rectangular and circular sections – chimneys subjected to uniform wind pressure – chimneys of square & circular cross sections only – problems.

UNIT – 5

20 Hours

5.1 Masonry dams

Introduction – derivation for maximum and minimum stresses – stress distribution diagrams – Problems – Factors affecting stability of masonry dams – factor of safety problems on stability – minimum base width & maximum height for no tension – Elementary profile of a dam – Minimum base width of elementary profile for no tension.

5.2 Earth pressure and retaining walls

Definition – Angle of repose – state of equilibrium of soil – Active and passive earth pressure – Rankine's theory of earth pressure – Assumptions – lateral earth pressure with level back fill – level surcharge – earth pressure due to soils – Retaining walls with vertical

back only – maximum and minimum stresses – stress distribution diagrams – problems – stability of earth retaining walls – problems to check stability- Minimum base width for no tension.

Revision & Test

12 Hours

Reference Books :

1. S. Ramamrutham, "Theory of structures"
2. B.C. Punmia, Ashok Jain & Arun Jain," Theory of structures ",Laxmi Publications, 9th Edition, April1992.
3. S.B. Junnarkar, Mechanics of structures (Vol.I) Charator Publiching,22nd Edition,1997
4. V.N. Vazirani & M.M. Ratwani, Analysis of structures
5. R.L. Jindal , "Elementary Theory of Structures"
6. FV. Warnock, "Strength of materials ",

11042-Environmental Engineering

7 Hrs/Week

16 Weeks

112 Hours

Objectives:

- State the quantity of water for various needs and forecasting future population.
- Select suitable source of water supply and pipe materials used to convey water.
- Describe the quality of water and specifying BIS Standards.
- Describe various treatment process and different distribution system.
- Explain methods of collection and conveyance of sewage.
- Explain primary and secondary treatment of sewage and disposal.
- Identify the various pollutions and their prevention methods.
- Explain industrial waste treatment methods and solid waste disposal methods.
- Create awareness about Environment Management and disaster management system.

UNIT I
Hours

20

1.1 Quantity of water

Water supply-need for protected water supply-importance aspects of public water supply schemes-demand-types of demand-domestic demand, industrial and commercial demand, demand for public uses, fire demand, demand for compensating various losses-per capita demand - factors affecting the per capita demand - population forecast - methods of forecasting population-problems in arithmetical increase method, geometrical increase method, incremental increase method - total quantity of water required for villages/towns-sources of water - surface sources - lakes & streams, ponds, rivers and storage reservoirs-subsurface sources - Infiltration gallery, Infiltration wells - shallow wells - Deep wells, Tube wells – Selection of suitable source for a water supply scheme.

1.2 Collections and conveyance of water

Intake - Types of intakes - description of canal intake reservoir intake, river intake - methods – conveyance of water – methods - pipe materials - cast iron, steel, G.I, cement concrete & R.C.C and P.V.C pipes - advantages and disadvantages of different pipes - joints in pipe lines - spigot and socket joint, Expansion joint, Flanged joint, Collar joint and joint for A.C. pipes – Laying and testing of pipe lines - Recharging ground storage- Rain water harvesting

1.3 Quality of water

Meaning of pure water – Requirements of potable or domestic water - Impurities in water - Sources, causes and effects of different types of impurities – Water Analysis -physical, Chemical and Bacteriological tests - standards laid down by B.I.S.I for drinking water –

Living Organism in water-W.H.O standards - Maintenance of purity of water - water borne diseases and their causes.

UNIT II
Hours

20

2.1 Treatment of water

Layout of treatment plants – sedimentation – plain sedimentation, different types of sedimentation tanks – sedimentation with coagulation - common coagulants – choice of coagulants - Filtration - Theory of filtration -Types of filters - Description - Rapid sand Filters – Pressure filter (Horizontal type only) - Disinfection of water – Methods of Chlorination - Forms of chlorination - Dosage of chlorine - Mineral waters – Requirements - Treatment processes - Reverse Osmosis process.

2.2 Distribution system

Different systems of supplying water - Gravity system, Pumping system and combined system- Continuous and intermittent supply of water- Different layouts of distribution systems – Dead end, Grid iron, Radial and Circular systems – Merits, demerits and suitability of different layout systems – Service reservoirs – underground and over head tanks.

UNIT 3
Hours

20

3.1 Collections and conveyance of sewage

Sanitation – purpose – Definition of terms – sewage, sewer, sewerage, sullage, refuse and garbage – properties of sewage - physical and chemical bacteriological BOD, COD – Methods of carrying sewage water – water carriage system – Quantity of sewage - Variation in rate of flow of sewage – Estimation of quantity of sewage – problems – minimum size of sewer – shapes of sewer – circular and non circular shapes (names only) – Reasons for selecting circular shapes – Gradient of sewer lines – minimum and maximum velocities in sewers – Self Cleaning Velocity-Materials used for sewers – Laying of sewers lines – Joints in sewer lines – Testing of sewer lines – Ventilation of sewers – Cleaning of sewers – sewer appurtenances – manhole – lamp hole – catch basin – Flushing tank – Drainage arrangement in buildings – Sanitary fittings – W.C., Flushing cisterns, Traps – P,Q,S only Maintenance of House drainage system – Sewage pumps – Types of sewage pumps(names only).

UNIT 4
Hours

20

4.1 Treatments and disposal

Schematic diagram of sewage treatment plant – Treatment of sewage – Primary treatment – Screens – Skimming Tanks – Grit chambers – Sedimentation Tanks – objects – principles of sedimentation – Classification – primary and secondary – secondary treatment - standard rate and High rate Trickling filters – Activated Sludge process – Septic Tanks for isolated buildings – Components and working of Septic tanks – Standard size of septic Tank for Houses and Institutional Buildings-Disposal of Septic Tank effluent – Soak pits, Dispersion Trenches- use of treated effluent-Schematic Diagram of Sullage water Treatment plant in Multistorey Residential Flats and small Colony – Advantages.

UNIT 5

20

Hours

5.1 Industrial waste water treatment and refuse disposal

Industrial waste – Principles of Industrial waste water treatment – List of Industries producing harmful Wastewater – Water Pollution by Industrial Waste water –Treatment Processes (Schematic Flow Diagram only)usually adopted for – Tanneries- Textile mills – Sugar mills – Solid waste – Separation of Waste - Disposal of Solid Waste – Necessity – Collection and Conveyance of Solid Waste – Methods of disposal – Dumping , Sanitary Land filling, Incineration, Composting and Salvaging.

5.2 Environmental pollution and control

Environment - Definition – Water pollution – Sources of water pollution – Effects and prevention of water pollution-Land pollution – Sources of land pollution – Effects and prevention of Land pollution – Pollution impact on land due to non – biodegradable waste matters (polythene bags, P.V.C. & other plastic materials, Glass, etc.,) – Remedial measures - Air Pollution – Classification of Air Pollutants – Sources – Natural and Man made sources – Effects of Air Pollution on human beings, animals, plants and materials – Control of Air Pollution – Different Equipments to control Air Pollution – Settling chambers, Cyclone and Electrostatic precipitators – Forest Management –Direct benefit from forest – deforestation causes and effective measures to conserve the forest wealth - Environmental degradation – Green House effect – Ozone layer depletion – Acid Rain. Noise pollution management – Effects of noise on people – Noise control methods - Functions of Ministry of Environment and Forest – Environment protection Laws in India- The water Act 1974(prevention and control of pollution)-The air act 1981- The Environment protection act 1986 – objectives only.

Revision & Test**12 Hours**

Reference Books:

1. S.K. Garg," Water supply and Sanitary Engineering" Kanna publishers, Delhi 5th Edition , 2001.
2. K.S. Rangwala, " Water supply and Sanitary Engineering"
3. G.S. Birdie and JS. Birdie," Water supply and Sanitary Engineering" Dhanpat rai publishers Delhi, 6th Edition,2002.
4. Suresh K.Dhamija,"Environmental Studies", S.K.Katarial Sons Delhi, 2nd Edition, 1998
5. Rao & Dutta,"Industrial waste water treatment"
6. M.N. Rao & H.V. Rao," Air pollution ",19th Edition, 1989, Tata Mcgrawhill Publishing Company Ltd.

11043 – TRANSPORTATION ENGINEERING

6Hours/week

16 weeks

96 Hours

Objective :

- Define the Highway planning, development, classification of roads and Traffic signals.
- Study on sub grade soil ,Road Arboriculture and Road Machinery.
- Construction procedures of Low cost ,WBM. Bitumen, Concrete and Hill Roads.
- Define Railway, Development and study on Materials used in Railways.
- Study on fixtures used in Track, points and Crossing and Signaling.
- Introduction on Bridges, classification and IRC Loading .
- Study of foundation, substructure and superstructure of Bridges.

A. Highway

UNIT 1

18 Hours

Principles of Highway Engineering

1.1 Introduction

Role of Road Transportation – Highway planning in India – Indian Road Congress – Nagpur Plan – Ribbon development – classification of Roads – Requirements of an ideal road – List of National Highways and State Highways in Tamilnadu.

1.2 Technical Features of a Road

Road structure – Road Camber – Super elevation – Road Gradient – Sight Distances – curves - Horizontal curves - Vertical curves -Types.

1.3 Traffic Engineering

Traffic Signals – Advantages – Types of Road signs – purpose – Traffic Surveys – Express ways – Necessity and Requirements – Grade Intersections – Grade separations – Location – Types – Road Accidents _ causes of accidents – Preventive measures.

1.4 Highway Pavements

Objective of Pavement – classification – Flexible Pavements, Rigid Pavements – Functions of pavement components – Comparative study of Flexible Pavement and Rigid Pavement.

1.5 Sub grade Soil

Significance of sub grade soil – Three phase system of soil mass – Grain size Distribution – Atterberg limits – IS classification of soils – Factors affecting sub grade soil strength – compaction – standard Proctor compaction test – Tests for evaluation of soil strength – Direct shear test – California Bearing Ratio test..

1.6 Road Arboriculture

Need of planting Trees – Selection of Trees – Location of Trees – Highway Lighting – Benefits.

UNIT 2

16 Hours

Highway Construction

2.1 Highway Alignment and Survey

Basic requirements of an ideal alignment – Survey for Highway Location – Reconnaissance survey , Preliminary survey , Location survey – New Highway Projects – Various steps –Realignment Project – its necessity.

2.2 Road Machineries

Excavation Equipments – Bulldozer, Scraper, Power Shovel, ClamShell, JCB Excavator – Compaction Equipments – Smooth wheeled roller, Pneumatic tyred roller, Vibratory roller, sheep foot roller – Equipment for shaping the sub grade – Grader – Equipment for Bitumen Road – Paver-Finisher.

2.3 Low cost Roads

Earthen and Gravel Roads – Construction Details with sketches – Maintenance – Soil stabilization.

2.4 Water bound Macadam Road

Materials used – Construction Details with sketches – Maintenance.

2.5 Bituminous Roads

Bituminous materials – Asphalt – Tar – Cutback – Emulsion – Test on Bitumen – Flash and Fire point test – penetration test – softening point test – Types of Bituminous Roads – Surface dressing – Semi grouting – Full grouting – Bituminous Concrete –Maintenance of Bituminous Roads.

2.6 Concrete Roads

Classification of concrete Road – Construction Details.

2.7 Hill Roads

Factors considered in alignment – Formation – Hair pin bends – Retaining and Breast walls.

B. RAILWAY

UNIT – 3

17 Hours

3.1. Introduction

Introduction – History – Development – Definition – Classification of Indian Railways - Gauges – Broad gauge – Narrow gauge – Meter gauge –

Loading gauge – Construction gauge - Difficulties in having different gauges

3.2. Rails

General – Rail function – Types of Rail sections – Comparison of rail sections – Kinds of rails – Length of rails – welding of rails – Coning of wheels – Bending of rails – Creep – Wear of rails – Hogged rails.

3.3. Sleepers and ballast

Functions of sleepers – Types of sleepers – Wooden, Cast Iron Prestressed concrete sleepers – Requirements of good sleepers – Sleeper density – Functions of ballast – Characteristics of good ballast – Ballast materials.

3.4. Track fixtures, fastenings and plate laying

Rail joints – Fish plates – Fish bolts- Fang bolts- Hook bolts – Rail chairs and keys – Bearing plates – Blocks – Spikes-Elastic fastenings- Anchors & Anti creepers – Plate laying – Different methods - PQRS method of relaying .

3.5. Maintenance of track

Necessity – Maintenance of track materials, Bridges & Rolling stocks.

UNIT – 4

16 Hours

4.1. Points and Crossings

Purpose and definition of points and crossings - Turnouts – Points and switches – Types of switches - Sleepers laid for Points and Crossings – Types of Crossings.

4.2. Stations and yards

Definition of station and yard – Types of stations – Wayside stations – Junctions and Terminal station – Classification of yards – Passenger yard – Goods yard – Marshalling yard – Level crossing.

4.3. Station equipments

General – Engine sheds – Water columns – Drop pits – Turnouts – Turn tables – Triangles – Buffer stops – Fouling marks – Sand hump – Weigh bridges.

4.4. Signalling

Objects of signalling – Types – Classification according to location – Special signals – Typical layouts – Control of movement of trains –

Following train system – Absolute block system- Automatic signaling – Pilot guard system – Centralised traffic control system.

4.5. Interlocking

Definition – Essential principles of interlocking – Methods of interlocking – Tappets and lock system and key system.

C. BRIDGES

UNIT – 5

17 Hours

5.1. Introduction

Bridge definition – Components of a bridge – IRC loading – Selection of type of bridge – Scour – Afflux – Economic span – Waterway.

5.2. Site selection and alignment

Factors governing the ideal site selection – Alignment of Bridges – Points to be considered .

5.3. Classification of bridges

Classification according to IRC purpose, Materials, Life, Float position, Culverts and Cause ways – Classification of Culverts with sketches – Classification of Causeway – Condition to construct Causeway.

5.4. Foundation

Function of foundation – Depth of Bridge foundation – Different types of foundation - Selection of foundation – Control of ground water for foundation – Caisson foundation – Cofferdam.

5.5. Substructure

Piers – Different types of Piers – Abutments – Types – Wingwalls – Types.

5.6. Superstructure

Types - Description – Girder Bridges – Balanced Cantilever bridges - Continuous bridges – Arched bridges – Suspension Bridges – Cantilever Bridges – Steel Arched bridges – Rigid frame steel bridges – Bowstring girder bridges – Continuous steel Bridges

5.7. Bridge bearings

Purpose of bearings – Function – Types of bearings & suitability-Elastomer Bearings.

REVISION & TEST

12 Hours

Reference:

1. Kadiyali L R, Principles and Practice of Highway Engineering, Khanna Technical Publications, Delhi, 2000.
2. Khanna K and Justo C E G, Highway Engineering, Khanna Publishers, Roorkee, 2001.
3. IRC Standards (IRC 37 - 2001 & IRC 58 -1998)
4. Bureau of Indian Standards (BIS) Publications on Highway Materials
5. Saxena Subhash C and Satyapal Arora, "A Course in Railway Engineering", Dhanpat Rai and Sons, Delhi, 1998.
6. P.A. Krishnamoorthy Highways Engg
7. Rangwala, Railway Engineering, Charotar Publishing House, 1995.
8. J.S. Mundrey, "A course in Railway Track Engineering".
9. T.D. Ahuja & G.S. Birdi Roads, Railways & Bridges

11044-MATERIAL TESTING LAB PRACTICE – II

3ours/week

16 weeks

48 Hours

Objectives:

- Test on properties of fine aggregate and coarse aggregate.
- Test on properties of soil.
- Analysis the properties of water/waste water.

Part – A

15Hours

1. Determination of VOIDS in sand bulk density
2. Determination liquid limit and plastic limit of soil
3. Determination of field density of soil
 - a. Sand pouring cylinder method
 - b. Core cutter method
4. Proctor's compaction test
5. Direct shear test on sand

Part – B

18 Hours

1. Determination of Specific gravity of soil/sand.
2. Determination of Specific gravity of aggregates.
3. Attrition test on aggregate
4. Abrasion test on aggregate
5. Aggregate impact test
6. Crushing strength of aggregate
7. Water absorption test on coarse aggregate

Part – C

9 Hours

1. Determination of Total solids present in the given sample of water.
2. Determination of Turbidity of water by "Jackson Candle Turbidity meter".
3. Determination of settle able solids present in the given sample of water / waste waster by "Imhoff Cone".

Part-D

6 Hours

1. Preparation of report of soil collected in his locality.
2. Collection of photos about a road project and preparation of a detailed report.
(5 Marks allotted in the Internal assessment of 25 Marks.)

Scheme of Examination

1. In the examination, the students have to be given either one question from Part A or two questions, one from part – B and one from part C.

List of equipments

1. Pycnometer
2. Balance, Oven, Glass Plate, China Clay Disc etc.
3. Devals Attrition testing machine
4. Dorry's Abrasion testing machine
5. Aggregate Impact testing machine
6. IS sieve all size
7. Standard Liquid limit device
8. Sand pouring cylinders

9. Cylindrical core cutter
10. Proctor compaction mould with accessories
11. Direct shear machine with Shear box assembly

List of Materials

1. Sand, Water, Coarse Aggregate 20mm & 40mm, Soil sample etc.

11045- CAD IN CIVIL ENGINEERING DRAWING PRACTICE -I

6 HOURS/WEEK

16 WEEKS

96 HOURS

Objective:

- Study on the available Software packages for drafting.
- Thorough knowledge of available commands in the software packages for the preparation of drawing in the computer.
- Practice on Drawings, simple drawings to be drawn in the computer with the available software packages.
- Practice on drawing- Residential, School, Hospital Buildings and Submission (for approval) drawings in the computer.

Preparation of drawing using available Software Packages (AUTOCAD, Pro.E etc.)

1. Introduction of Software Packages available for Preparation of Drawings

Definition of various commands used in Software package.	-3 Hrs
Simple Exercises for familiarizing the drawing commands in software Package (AUTOCAD, Pro-E etc.)	-6Hrs

2. Draw the Given drawings in Computer and take print out of all drawings in A4 sheet using INKJET/LASER PRINTER or PLOTTER and produced in file forms as regard.

2.1 Section of semicircular Arch	-3Hrs
2.2 Elevation of door partly paneled and partly glazed	-3 Hrs
2.3 Preparation of Plan showing arrangement of furnishers/fixtures and other futures with standard sizes for the followings (Each room to be drawn separately-futures and furniture's may be pasted from the Blocks available in the packages) (i) Living (ii) Bed Room (iii) Kitchen (iv) Toilet	-9Hrs
2.4 Steel Structures : Cross section of, I , Channel, T , Angle and Tubular section, Compound Beam and Plate Girder	-3Hrs
2.5 Section of Load bearing wall from parapet to foundation Partly showing all the details across the section.(Single storey)	-3 Hrs
2.6 Plan, Section and Elevation of single bed roomed building (R.C.C. Roof)	- 9 Hrs
2.7 Plan, Section and Elevation of Double bed roomed building (R.C.C. Roof)	- 9 Hrs
2.7 Plan, Section and Elevation of a Primary School Building	- 9 Hrs
2.8 Plan, Section and Elevation of a Hospital Building	- 9 Hrs
2.9 Small Workshop with steel column, Steel roof truss	

and Metal sheet Roofing - 9 Hrs

2.10 Preparation of approval drawing to be submitted to Corporation or Municipality showing required details in one sheet such as - 9 Hrs

- a. Site Plan (Land boundary, Building boundary, Car Parking, Passage, sanitary layout, septic tank location etc.
- b. G.F. Plan, F.F. Plan, Section and Elevation(line diagram is enough)
- c. Key Plan
- c. Septic tank Plan and section (line diagram)
- d. Rain water harvesting pit (with all detail)
- e. Typical foundation details (Column foundation or spread footing)
- f. Title block showing – joinery details, Specification, Area statement, color Index Title of the property, space for owners Signature and Licensed Surveyor’s Signature and Planner Company Address etc.

Revision & Test

12 Hours

List of Equipments

- | | | |
|-----------------------------------|---|---------|
| 1. Models of Structures | - | 1 Each. |
| 2. Computers Pentium IV | - | 30 Nos. |
| 3. Auto CAD Software - Multi user | - | 1 No. |

11046- SURVEY PRACTICE II

6 Hours / Week

16 Weeks

96 Hours

OBJECTIVES:

- Study on Component parts of Theodolite.
- Exercises on measurement of Horizontal and Vertical angle by Theodolite.
- Determine the Height of an object by Single plane & Double plane Method.
- Study on Tachometer.
- Determination of Elevation of an object using Tachometer.
- Distance & Co-ordinates of the given points using Total Station
- Study on Total Station.
- Measurement of distance and co-ordinates using Total Station.
- Traverse using Total Station.

PART- A

1. Theodolite

36 Hours

- 1.1 Setting up of Theodolite – Temporary Adjustment – Reading horizontal angles
- 1.2 Measurement of horizontal angle:
 - a. By reiteration method (not for Exam)
 - b. By repetition method (not for Exam)
- 1.3 Determination of distance between two points when their base accessible using Theodolite by measuring Horizontal angles by repetition method and distances from a Theodolite Station.
- 1.4 Determination of distance between two points when their base inaccessible using Theodolite by measuring Horizontal angles by reiteration from a baseline.
- 1.5 Closed Theodolite Traverse measuring included angles.
- 1.6 Measurements of vertical angles
Height of the object when the base is accessible
- 1.7 Reduced Level of Top of an object when the base is inaccessible
 - a) Single plane method
 - b) Double plane method

PART- B

2. Tacheometry

24 Hours

- 2.1 Determination of constants of a tacheometer
- 2.2 Determination of distance and elevation of a point
by Tacheometric observations
- 2.3 Determination of gradient between two points of different elevations by stadia tacheometry
- 2.4 Tangential tacheometric observation

PART –C

3. Total Station

18 Hours

- 3.1 Study of Total Station
- 3.2 Measurement of distance and co-ordinates of given points minimum 6 points
- 3.3 Measurement of altitude of given elevated points
- 3.4 Traverse and plotting using Total Station (Local Points)

TEST & REVISIONS -**12 Hours****Survey Camp (Outside the Campus)****Duration 7 days****6 Hours**

Seven days survey camp using Theodolite, cross staff, Levelling staff, tapes, and Total station. The objective of the survey camp is to enable the students to get practical training in the field work. Groups of not more than six members in a group to be carried out each exercises of camp work. The camp must involve work on a large area of not less than 30 Acres out side the campus. At the end of the camp, each student shall have mapped and contoured the area. The camp record shall include all original field observations, calculations and plots.

15 marks to be allotted for survey file in the Examination

Works to be conducted in survey camp

- i) L.S and C.S for a canal / road alignment
- ii) Radial Tachometric contouring
- iii) Contouring by block levels
- iv) Curve setting by deflection angle
- v) Check levelling
- vi) Theodolite / Tacheometric traverse
(Balancing the traverse by Bowdich rule)

In Examination questions will be chosen are as follows:

PART- A & B	One question	- 45 Marks
PART- C	One Question	- 10 Marks
Survey Camp		- 15 Marks
Viva-Voce		- 5 Marks
Record		- 25 Marks
	TOTAL	- 100 Marks

List of Equipments:

1. Theodolite fitted with stadia hair and Analytic Lens - 15 Nos.
2. Total Station (Initially) - 2 Nos.

11041 – THEORY OF STRUCTURES

Model Question Paper - I

Time: 3 Hours

Max. Marks: 100

- Note :**
- 1 Answer ALL QUESTIONS from **PART - A** each carrying 1Mark
 - 2 Answer ALL QUESTIONS from **PART - B** each carrying 3Marks
 - 3 Answer ALL QUESTIONS from **PART –C** choosing either a or b each carrying 10 Marks

PART A

1. What is deflection of beam at free end for the beam carrying Point load at Free end.
2. Define Indeterminate Structure.
3. Draw the Bending moment diagram for the fixed beam carrying UDL throughout.
4. Define : Theoretical arch and Actual arch.
5. Define stiffness factor.
6. Define : Distribution factor and Distribution moment.
7. Draw the deflected shape of the column fixed at both end.
8. Define eccentric loading
9. Define angle of repose of soil.
10. Write the Rankine's total earth pressure formula, for the retaining wall retaining earth with angular surcharge.

PART B

11. State Mohr's area moment theorems.
12. Find the prop reaction of a propped cantilever beam subjected to UDL throughout the span by area moment method.
13. Brief the application of three moments equation for different end conditions.
14. Distinguish between short column and long column and write down the effective length of column for all the four case with necessary sketches.
15. What is an elementary profile of a dam? Sketch the same.

PART C

16. (a) A steel pipe 50mm internal diameter and 2mm wall thickness is simply supported on a span of 6m. If the deflection is limited to $\frac{1}{325}$ of the span, calculate the rate of loading on the beam. Also calculate the maximum slope at the supports. Take $E = 2 \times 10^5 \text{ N/mm}^2$.

(b) A beam of length 6m is fixed at one end and supported by a rigid prop at the other end at the same level. It carries an UDL of 5KN/m for a length of 4m from the fixed end Determine the prop reaction and draw SFD and BMD.
17. (a) A fixed beam of span 9m is subjected to an UDL of 20 KN/m over the entire length. It also carries two concentrated loads of 10KN each at 3m from the ends.
 - (i) Determine the values of fixing moments.
 - (ii) Sketch the BMD marking the maximum values there in. _

(b) A symmetrical three hinges circular arch has a span of 24m and rise of 5m. It carries UDL of 10kN/m over the entire length of the span. Determine the bending moment at quarter span points and sketch the BMD.

18. (a) Determine the support moments for the beam shown in figure (1) by Clapeyron's theorem of three moments. Draw the bending moment diagram. $E I$ is constant.

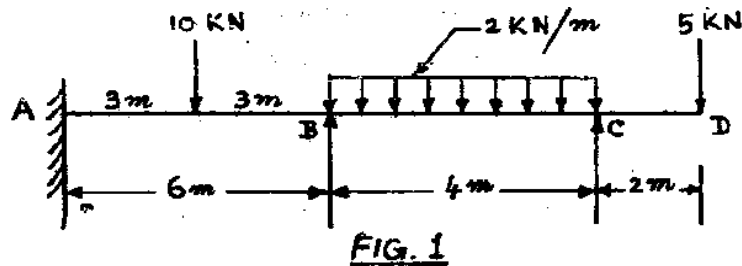

(b) Analyse the portal frame shown in figure (2) by moment distribution method. Draw the bending moment diagram.

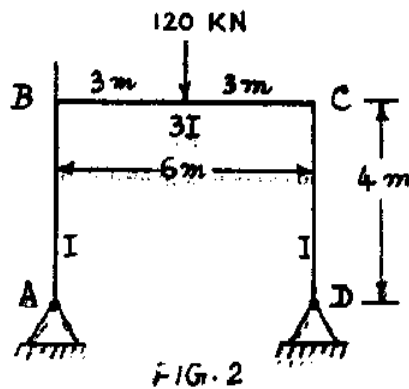

19. (a) A steel column consists of two channels ISMC 400 at 494 N/m placed back to back at a clear distance of 200mm and two plates of each 400mm x 10mm connected to the flanges on each side. Find the safe load on the built up column with a factor of safety of 3 by Rankine's formula. The column is 4.5m long fixed at one end and hinged at the other.

Take $\sigma_c = 320 \text{ N/mm}^2$ and $a = 1/7500$.

Properties of each channel are,

$$I_{xx} = 15082.8 \times 10^4 \text{ mm}^4 ; I_{yy} = 504.8 \times 10^4 \text{ mm}^4$$

$$C_{yy} = 24 \times 2 \text{ mm} ; A = 6293 \text{ mm}^2 ; bf = 100 \text{ mm}.$$

(b) A Chimney has external and internal dimensions of 2.4m x 2.4m and 1.2m x 1.2m respectively. The height of the chimney is 25m. Calculate the maximum and minimum stress intensities at the base when it is subjected to a horizontal wind pressure of intensity 1.5 kN/m^2 . Specific weight of masonry is 22 kN/m^3 . Also plot the stress distribution diagram.

20. (a) A trapezoidal dam 3m wide at top, 8m wide at the base is 12m high. It retains water upto a depth of 11m on the upstream vertical face. Take the weight of masonry as 24 kN/m^3 and that of water as 9.81 kN/m^3 . Check the stability of the dam for overturning and sliding if $\mu = 0.6$ and F.O.S. = 1.5.

(b) A retaining wall 6m high, 2m side at top and 4m wide at base retains earth to its full height on the vertical face. There is a road on the top of the retained earth which transmits a uniform surcharged load of 60KN/m^2 . Angle of repose of retained earth is 30° . Weight of earth is 18KN/m^3 . Weight of masonry is 24KN/m^3 . Calculate the magnitude and position of line of action of horizontal earth pressure per meter length of wall.

11041 – THEORY OF STRUCTURES

Model Question Paper- II

Time: 3 Hours

Max. Marks: 100

- Note :**
- 1 Answer ALL QUESTIONS from **PART - A** each carrying 1Mark
 - 2 Answer ALL QUESTIONS from **PART - B** each carrying 3Marks
 - 3 Answer ALL QUESTIONS from **PART –C** choosing either a or b each carrying 10 Marks

PART A

1. What is the slope at support of a simply supported beam carrying point load at mid span.
2. Define : Slope and Deflection.
3. What is fixed beam and how it differ from – A simply supported beam.
4. What are the different types of arches.
5. Define distribution factor.
6. What is carry over factor?
7. Define : Slenderness ratio.
8. What is the effect of wind pressure acting on chimneys?
9. Define middle third rule.
10. What are the failure of Dams.

PART B

11. A cantilever loaded with a point load at center of the span is propped at the free end. Find the fixed support moment and prop reaction.
12. A fixed beam of 6m. span subjected to a UDL of W/m over its full length. The net BM at center is 30 KN/m. Find the value of W .
13. How do you analyze a continuous beam by Hardy cross method?
14. Derive the Kern of section for a circular column?
15. A trapezoidal masonry dam having 12m. height retains water to a height of 10m. on its vertical face. Find the horizontal water pressure if $r = 9.81 \text{ KN/m}^8$.

PART C

16. (a) A simply supported beam of 4 m. span carries an UDL of 10 KN/m. over the full length and a mid point load of 20 KN. Determine the maximum slope at the supports and the maximum deflection at center by moment area method.

(b) Construct SFD and BMD for a propped cantilever of length 5m. with end prop carrying two point loads of 5 KN, 10 KN at 2m. and 3m. distances respectively from the fixed end.
17. (a) A fixed beam of span 8m. is subjected to an UDL of 4 KN/m. over a length of 4m. symmetrically placed at the center portion. Determine the support moments and draw the BMD.

(b) A three hinged parabolic arch ABC of span 20m. and central rise of 5m. at "C" carries a point load of 20 KN at 6m. from the left hand support. Find the reaction at the supports A and B.
18. (a) A beam ABCD, 9m. long is simply supported at A, B and C, such that the span AB

is 3m., span BC is 4.5m. and the overhanging CD is 1.5m. It carries a UDL of 1.5 KN/m. in span AB and a point load of 1 KN at the free end. The MI of the span AB is I and that in span BC is $2I$. Compute the support moments by moment distribution method.

(b) Compute the support moments by Hardy cross method for the two span continuous beam ABC with simply supported ends. All carries an UDL of 20 KN/m. BC carries a point load of 90 KN at 2m. from B. $I_{BA} = I$, $I_{BC} = 2I$.

19. (a) An ISJB 150 is used as a pin ended column of 1.8m. length. Calculate the safe load on the column using a factor of safety of 3. The properties of ISJB 150 are $A = 901 \text{ mm}^2$, $I_{xx} = 3 \times 10^6 \text{ mm}^4$, $I_{yy} = 9 \times 10^4 \text{ mm}^4$ and $E = 2 \times 10^5 \text{ N/mm}^2$.

(b) A cylindrical chimney 20m. height of uniform circular cross section is 5m. external dia and 3m. internal dia. The intensity of horizontal wind pressure is 1.5 KN/m^2 . Find the maximum and minimum normal stress intensities at the base, if the specific weight of masonry is 22.5 KN/m^3 .

20. (a) A trapezoidal masonry dam having 3m. top width, 8m. bottom width and 12m. High retains water to a height of 11m. on its vertical face. Check the stability of the dam, if the masonry weights 20 KN/m^3 and co-efficient of friction between the bottom of masonry and soil is 0.6. Take allowable compressive stress as 400 KN/m^2 and weight of water as 9.81 KN/m^3 .

(b) A retaining wall trapezoidal in section 8m. high 1m. wide at top 3m. wide at bottom with a vertical face retains earth level with the top of the wall. If the weight of the masonry is 24 KN/m^3 and that of earth is 18 KN/m^3 , with an angle of repose of 40° . Calculate the maximum and minimum stresses at the base.

11042-Environmental Engineering

Model Question Paper - I

Time: 3 Hours

Max. Marks: 100

- Note :** 1 Answer ALL QUESTIONS from **PART - A** each carrying 1Mark
2 Answer ALL QUESTIONS from **PART - B** each carrying 3Marks
3 Answer ALL QUESTIONS from **PART - C** choosing either a or b each carrying 10 Marks

PART - A

1. Name the method in which the average increase in population for a period is assumed to be constant.
2. What are the Types of Intakes.
3. Write the quantity of total solids permitted in drinking water as per BIS
4. What are the common coagulants used in treatment of water.
5. Define Sewage.
6. Define BOD
7. Define soak pit.
8. Define Acid Rain
9. Define Environment
10. List the industries producing harmful wastewater.

PART - B

11. What do you mean by variation in demand?
12. State any four impurities in water
13. Explain the Water carriage system and What do you mean by Activated sludge
14. Explain Primary Treatment of sewage.
15. What do you mean by solid waste and Write any four effects of Deforestation

PART -C

16. a. i. Explain the various sources of water supply scheme
ii. Draw the different layouts of distribution system.
Or
b. i. Explain with sketch Infiltration Gallery.
ii. Explain the types of pipes used in water line with their merits and demerits
17. a. i. How will you conduct Bacteriological tests in a sample of water?
ii. Explain the methods of chlorination.
Or
b. i. Explain mineral water treatment process with neat sketch.
ii. Explain briefly the construction and working of a Rapid sand filters
18. a. Describe briefly the following with neat sketches
i. Dead end system ii. Radial system
or
b. i. Explain with example the estimation of quantity of sewage.
ii. Explain the types of pipes used in sewage line with their merits and demerits.
19. a. Explain with a neat sketch construction and working of a Trickling filter
or
b. Draw the neat sketch of septic tank and mark the salient features.

20. a. i What are the effects of air pollution on human beings and plants
ii How will you conserve water in municipality, agriculture land and industrial?
Or
b. Describe the treatment process adopted for sugar mill waste water.

11042 - Environmental Engineering and Management

Model Question paper - II

Time: 3 Hours

Max. Marks: 100

- Note :** 1 Answer ALL QUESTIONS from **PART - A** each carrying 1Mark
2 Answer ALL QUESTIONS from **PART - B** each carrying 3Marks
3 Answer ALL QUESTIONS from **PART -C** choosing either a or b each carrying 10 Marks

PART A

1. What do you mean by per capita demand?
2. What are the various Pipe materials normally used
3. Define Chlorination.
4. What are the advantages of Rapid sand filters?
5. Define BOD and COD
6. Define Manhole?
7. What do you mean by Activated sludge?
8. Define Septic Tank
9. Define Recycle and reuse.
10. What are the different equipments to control Air Pollution.

Part B

11. Explain the geometrical increase method of population forecast with example.
12. Draw the schematic diagram ;of rapid sand filter and mark the all medias.
13. Explain the methods of carrying sewage.
14. Draw the schematic diagram of sewage treatment plant.
15. Write any four points of Land pollutions and Define Ozone layer.

Part C

16. a. What are the various types of Demands and explain the factors affecting the demands.
or
b. Explain the following pipe joints with neat sketches
i. Flanged joint ii. Collar joint iii. Spigot and socket joint
17. a. i. Explain the various Impurities in water and it is effects.
ii Draw the sketch of sedimentation tank.
Or
b. i. Explain the different system of supplying water.
ii. Explain briefly the construction and working of Rapid sand Filter
18. a. i. Discuss the various methods used in Ventilation of sewers
ii. Explain Maximum velocity, minimum velocity and self cleansing velocity in a sewer line.
or
b. Draw the sketches of all sewer appurtenances.
19. a i With a flow diagram explain Activated Sludge process.
ii Draw schematic diagram of sullage water treatment plant in Multistory residential flats.
Or
b.i Draw Grid chamber and skimming tanks.

- li Explain the object of sedimentation tank.
20. a.i Explain briefly the source, effects and prevention of Land pollution
ii Describe the treatment process adopted for Textile mill waste water
or
- b. I Explain the disposal of solid waste.
 - li What are the causes and effects of deforestation and suggest suitable methods to conserve the forest wealth.

11043 TRANSPORTATION ENGINEERING

Model Question paper - I

Time: 3 Hours

Max. Marks: 100

- Note :** 1 Answer ALL QUESTIONS from **PART - A** each carrying 1Mark
2 Answer ALL QUESTIONS from **PART - B** each carrying 3Marks
3 Answer ALL QUESTIONS from **PART -C** choosing either a or b each carrying 10 Marks

PART A

1. What is super elevation?
2. Distinguish between Road camber and Road gradient.
3. Write down types of Road Rollers
4. What is called 'cross drainage of Hill Roads'?
5. Write any two functions of Ballast.
6. What is Turn table?
7. What are the two methods of laying sleepers for points and crossings
8. State the principles of Interlocking.
9. Distinguish between causeway and bridge.
10. What do you mean by Scour?

PART B

11. What do you mean by Ribbon development? Suggest any two remedial measures.
12. Explain the Construction details with sketches of Water Bound Macadam Road.
13. Write any five functions of Sleepers.
14. What are the arrangements to be provided in Junction Stations?
15. Write short notes on the types of wing walls.

PART C

16. (a) What is meant by Sight Distance? Explain various types with sketches.
(b) Explain Standard Proctor Compaction test to determine Moisture- Density relationship of soils
17. (a) Explain various stages involved in a Highway Project.
(b) Explain method of construction of Water Bound Macadam Road with sketch,
18. (a) What is meant by Plate laying ? Explain any two methods of plate laying.
(b) What is meant by Creep? List out its causes and effect.
19. (a) What is meant by Turn out? Explain component parts of left hand turn out with sketch.
(b) List out the methods used for the control of movements of trains. Explain any one method.
20. (a) What are the points to be considered for site selection and alignment of bridges?
(b) With neat sketches explain the Bowstring girder bridge and Rigid frame steel bridge.

11043 - TRANSPORTATION ENGINEERING

MODEL QUESTION PAPER – II

Time: 3 Hours

Max. Marks: 100

- Note :** 1 Answer ALL QUESTIONS from **PART - A** each carrying 1Mark
2 Answer ALL QUESTIONS from **PART - B** each carrying 3Marks
3 Answer ALL QUESTIONS from **PART –C** choosing either a or b each carrying 10 Marks

PART A

1. What do you mean by compaction?
2. Define Atterberg limits.
3. Define Surface Dressing
4. What is called 'Highway Realignment Project'?
5. What is meant by wear of Rail?
6. Write any two advantages of welding of rails.
7. Write types of Crossings.
8. Write down the functions of Goods yard
9. Write any two functions of Bridge Bearings
10. What is Scour?

PART B

11. What is 'Traffic Volume study' and Speed study'?
12. Explain the construction details of concrete Roads with neat sketch.
13. Explain the different methods of plate laying.
14. Explain loading gauge with sketch.
15. What is Cofferdam? Explain any one type with sketches.

PART C

16. (a) Draw a cross-section of a road structure and describe its component parts in detail
(b) What are the causes of road accidents and mention the methods of prevention of accidents in roads?
17. (a) Explain the different operations involved in the construction of cement concrete road.
(b) What are the points to be considered while aligning a Hill road?
18. (a) What are the characteristics of good ballast material. Briefly explain various materials which are commonly used as ballast.
(b) What is meant by Plate laying? Explain in detail the PQRS method of plate laying.
19. (a) Explain in detail the types of stations based on their functional utility.
(b) Distinguish between Absolute Block system and Automatic signaling
20. (a) What are Causeways? List out the three classifications of causeways and explain any one in details
(b) What are the functions of foundation? What are the factors to be considered in the selection of foundation for a bridge?

V-SEMESTER

11051 – STRUCTURAL ENGINEERING

7 Hours / Week

16 Weeks

112 Hours

PART – A : REINFORCED CONCRETE STRUCTURES

UNIT 1

20 Hours

1.1 General

Reinforced Cement Concrete – Concept of Composite material – Purpose of providing reinforcement – materials used in R.C.C and their requirements – different grades of cement and steel – Characteristic strength and grades of concrete – modular ratio of R.C.C – types of loads on structures as per (IS: 875)

1.2 Introduction to working stress method (concept only)

Assumptions made in the working stress method – Permissible stresses (IS: 456-2000) – Flexural members – singly reinforced rectangular sections – strain and stress distribution due to bending. (No Design or Moment of resistance problems in working stress method)

1.3 Introduction to limit state method

Concept – different limit states- Characteristic strength and design strength of materials – Characteristic loads and design loads - partial safety factors for loads and material strength Limit state of collapse in flexure – assumptions – stress strain curves for concrete and steel – Stress block – maximum strain in concrete – limiting values of neutral axis for different grades of steel – moment of resistance of singly/doubly reinforced rectangular sections – problems.

1.4 Design of beams for flexure by I.s.m

Effective span of cantilever, simply supported and continuous beams – breadth and depth requirements of beams – control of deflection – minimum depth requirement for stiffness – minimum concrete cover for durability and fire resistance – minimum and maximum reinforcement, spacing for main reinforcement and side face reinforcement as per IS 456-2000-design bending moments – Design of singly and doubly reinforced rectangular beams –cantilever, simply supported beams-Solving Problems using Design Aid Sp16 for practice (not for Exam).

UNIT 2

20 Hours

2.1 Design of t-beams and continuous beams by I.s.m

Design of singly reinforced T-beams – cantilever/ simply supported beams- Design of continuous beams using B.M. coeffs (equal spans & u.d.l only) – use of design aids (not for examination) – Design of Lintel simple problems(not for Exam.)

2.2 Design of beams for shear by I.s.m

Limit state of collapse in shear – design shear strength of concrete – design strengths of vertical / inclined stirrups and bent up bars in shear – principle of shear design – critical sections for shear – nominal shear stress – design of vertical stirrups, inclined stirrups and bent up bars for rectangular beams using limit state method –simple problems- use of design aids (not for exam).

UNIT 3

22 Hours

3.1 Design of one way slabs by I.s.m

Classification of slabs – Effective spans - Imposed loads on slabs (IS: 875) – strength and stiffness requirements – minimum and maximum permitted size, spacing and area of main and secondary reinforcement as per IS 456 -2000 Design of cantilever, simply supported, slabs and sunshades by limit state method – Design of continuous slabs using B.M coefficients- check for stiffness – curtailment of tension reinforcement – use of design aids (not for exam).

3.2 Design of two way slabs by I.s.m

Introduction –Effective span –thickness of slab for strength and stiffness requirements Middle and edge strips – B.M coefficients – design B.Ms. – simply supported and restrained slabs – tension and torsion reinforcement requirement– design of two way slabs using B.M. coeffs – curtailment of reinforcement – check for stiffness.

3.3 Design of staircases by I.s.m

Types of stairs according to geometry and structural behavior planning a staircase – effective span of stairs – effective breadth of flight slab- distribution of loads on flights – design of cantilever steps – design of doglegged and open well stairs spanning parallel to the flight.

UNIT 4

18 Hours

4.1 Design of columns by I.s.m

Limit state of collapse in compression – assumptions - limiting strength of short axially loaded compression members - effective length of compression members – slenderness limits for columns – classification of column-minimum eccentricity for column loads – longitudinal and transverse reinforcement as per I S 456-2000-Design of axially loaded short columns with lateral ties / helical reinforcement – Use of design aid (not for exam).

4.2 Design of column footings

Types of footings – Footings with uniform thickness and sloped footings – minimum thickness – critical sections – minimum reinforcement ,distribution of reinforcement, development length, anchorage, cover, minimum edge thickness requirements as per IS 456-2000 – Design of isolated footing (square and rectangular) with uniform/ varying thickness by limit state method- For Examination (i) Problems on Design of Size of Footing and area of steel only.

(ii) For given sizes and other required details of the footing, check for Punching shear and Transverse shear only.(any one problem)

PART B - STEEL STRUCTURES

UNIT 5

20 Hours

5.1 Design Of Simple Beams

Classification of beams – lateral buckling of beams – assumptions – permissible bending and shear stresses (IS: 800) – minimum thickness of elements – limiting deflection of beams – Design of laterally supported beams using single / double rolled steel sections (symmetrical cross sections only).

5.2 Design Of Tension Members

General – Permissible stress in tension – Net sectional area of tension members– Effective sectional area of Angles/T-sections connected by one leg/ flange (welded connections only) – Design of ties using single/ double angles, T-sections and channels.

5.3 Design Of Compression Members

Effective length of compression members – slenderness ratio – Permissible stress – minimum thickness of elements – effective sectional area – Design of single angle and double angle struts – Design of steel columns using rolled steel sections (symmetrical sections only) with or without cover plates. (Lacing and battens not included).

5.4 Design Of Welded Connections

Types of welds – size and effective area of welds – Permissible stresses – strength of fillet/butt welds – Lap and butt joints for plates and angles – Beam to beam and Beam to column connections (sketches only)- seat angle and web angle connections(sketches only).

Revision & Test

12 Hours

Reference Books:

1. S.R.Karve and V.L.Shah," Limit state Theory and Design of Reinforced Concrete",Pune Vidya Griha Prakashan,1986.
2. P C Varghese," Limit state Design of Reinforced Concrete",Prentice-Hall of India Pvt. Ltd",1997.
3. Dr.S.Ramachandra," Limit State Design of Concrete Structures",Scientific publishers, 2004.
4. Park.R and Pauley.T," Reinforced Concrete Structures,John Wiley & Sons, New York,1975.
5. Mallick and Rangasamy,"Reinforced Cement Concrete" Oxford-IBH,1982.
6. I S 456-2000 , I S 875-1974, I S 800 -1984
7. Explanatory hand book SP24, Design Aid SP 16,Detailing of Reinforcement SP 34
8. Dr.Ram Chandra," Design of Steel Structures, Vol-I", Standars Book House, New Delhi, Tenth Edition, 1999.
9. S.K.Duggal, Design of Steel Structures",Tata McGraw Hill, 2000.

11052 – QUANTITY SURVEYING

7 Hrs / Week

16 weeks

112 Hrs

Objectives :

- Define various types of estimates.
- Differentiate between Group and Trade system.
- Appreciate duties & essential qualities of a Quantity Surveyor.
- Apply various Units of measurements for works & materials.
- Write specifications & reports for various items of works.
- Prepare data for various items of works using Standard data & Schedule of Rates.
- Prepare detailed of various items of works for the given drawing by using Group System.
- Prepare detailed of various items of works for the given drawing by using Trade System.
- Calculate the value of a building & fix rent for a building adopting suitable method.

UNIT I

18 Hrs

1.1 Introduction

Estimation – Definition of Estimate – Approximate estimate – Detailed estimate - Revised estimate – Supplementary estimate – Sub estimate – Annual maintenance estimate – Repair estimate – Complete estimate.

1.2 Approximate Estimates

Approximate estimates – Types – Plinth area method – Cubical content method – Service unit method – Typical bay method – Simple problems on preliminary estimate of a building project.

1.3 Measurements & Material Requirement

Units of measurements for works and materials – Degree of accuracy in measurements -Deduction for openings in masonry, plastering and white washing area – Painting coefficient – out turn of works working out of materials requirements – cement, sand, bricks, aggregates etc based on thumb rules for different works.

1.4 Specification & Report Writing:

Specification – Necessity – Types of specifications – Essential requirements of specifications – Specifications for various items of works – steps involved in standard specification – Report writing – Points to be considered while writing a report – writing typical reports for works such as

- (i) Buildings – Residential / Hospital / School
- (ii) Laying a village road
- (iii) Construction of a bridge
- (iv) Water supply system for a village

UNIT II

18 Hrs

2.1 Preparation of Data

Data – Theory – Main and sub data – Observed data – lead statement - Schedule of rates – Standard data book – Sundries – Lump sum provision – Preparation of data using standard data and schedule of rates:

2.2 Rate Analysis

Brick and stone masonry – Lime concrete and cement concrete – Flooring works and weathering course – R.C. works for slab, sunshade, beam and column – Partition wall – Form works for beams and slabs – Road works, WBM and surface dressing – White washing and painting works – A.C. sheet roofing – Apron and revetment works in canals – Wall plastering – Ceiling plastering – Pointing – Plumbing and sanitary works in buildings.

UNIT III

24 Hrs

3.1 Stages Of Detailed Estimate

Taking off Quantities –Systems – Trade system – Group system – Advantages of group system – Methods – Long wall and Short wall method – Centre line method – Preparation of data – Abstract estimate – Lump sum provision and contingencies – Quantity surveyor – Duties – Essential Qualities.

3.2 Group System

Theory – Taking off and Recording Dimensions – Squaring Dimensions – Abstracting or Working up – Billing – Abbreviations.

3.3 Process Of Writing

Dimension paper – Timesing, Dimension, Squaring, Descriptive column – Cancellation of Dimensions – Descriptions – Spacing of Dimensions – Order of taking off. Squaring the Dimensions - Method of Squaring – Checking the Squaring – Casting up the dimensions.

3.4 Abstracting And Billing

Function of the Abstract – Order in the Abstract – Preparing the abstract – Casting and reducing the Abstract – Method of writing Bill – Checking the Bill.

3.5 Taking Off Quantities

Prepare detailed estimate using Group system and Take off quantities for all items of works in the following types of buildings:

- i. A single roomed building using Group system
- ii. A small residential building with two / three rooms with RCC roof.

UNIT IV

24 Hrs

Prepare detailed estimate using Trade system and Take off quantities for all items of works in the following types of buildings:

- (i) A small residential building with two / three rooms with RCC roof.
- (ii) Two Storied building (framed structure) with RCC roof
- (iii) Industrial buildings with AC/GI sheet roof with steel trusses.
- (iv) Community Hall with columns and T-Beams.
- (v) Septic tanks with dispersion trench / soak pit
- (vi) R.C.C slab culvert

UNIT V

16 Hrs

5.1 Valuation

Purpose of valuation – Types – Book value – Market value – Salvage value – Scrap value – Depreciation – Obsolescence – Sinking fund – Land valuation – Mortgage & Lease – Problems on valuation – Annuity – Definition & types only.

5.2 Rent Calculation

Fixation of rent – Outgoing – Gross & Net income – Years' Purchase – Capital cost – Standard rent – Market rent – Economical rent – Problems on rent calculation.

A mini project report shall be submitted by each student at the end of the semester on {Rates Of all Building Materials with available units in Market, Quotation from different agencies for the rate of Building Materials (minimum three),Preparation of comparative statements of building materials and finalization of lowest bidder for the supply of the materials by each student separately}-5 Marks allotted for the above report in the Internal Marks of 25.

Revision & Test

12 Hrs

Reference ;

1. IS Code of Practice – IS 1200
2. Civil Estimating, Casting and Valuation – Kalson Publication Ludhiuyana.
3. Rangawala," Estimating & Casting, Charotor Publishing, 8th Edition,1990.
4. N.A.Shaw," Quantity surveying & Valuation", Khana Publishers,2001.
5. PL Bhasin," Quantity Surveying" S. Chand & Co. IIIrd Edition,1992.
6. L.N.Dutta, Estimating and Costing, Dhanpat Rai & sons, IInd Edition,1986.
7. Bridie, "Estimating and Costing",1989.
8. Vazirani & Chandolu," Estimating and Costing" 2001.

E

ELECTIVE THEORY - I

11071a. CONCRETE TECHNOLOGY & ADVANCED CONSTRUCTION

5Hrs/Week

16 Weeks

80Hrs

Objectives:

- Materials used for concrete
- Fresh concrete preparation and strength of concrete
- Admixtures used in construction and special concrete
- Mix design of concrete & prestressed concrete, methods and applications etc.
- Causes and effect of fire in buildings and precautionary measures
- Study on earth quake and design concepts
- Deep excavation methods and pile foundation types.
- Study on maintenance and rehabilitation of buildings .

UNIT-I

14 Hrs

1.1 Materials For Concrete

Concrete- Cement-Composition and properties of portland cement Pozzolona cement- cement of different types- uses- Aggregate- I.S.code Specifications- Water – Requirements of water for concrete making-I.S.code specifications.

1.2 Fresh Concrete

Workability– Factors affecting workability – Water content – Measurement of workability- slump test- compaction factor test – Segregation – Bleeding –Process of manufacture of concrete – Batching –Mixing –Transporting concrete –Placing of concrete- compaction of concrete – curing of concrete – curing methods – Strength of Concrete – Factors affecting strength of concrete.

1.3 Admixtures

Definition – function – classification – Accelerators-Retarders-water reducing agents- Plasticizers-Air entraining agents-Water proofing admixtures-uses - I.S.specification

(9103

and 456)

1.4 Special concrete

Light weight concrete – polymer concrete – Fiber reinforced Concrete-self compacting concrete – Ferro cement-Applications -advantages and limitations.

UNIT – 2

14 Hrs

2.1 Mix Design for Concrete

Mix design-concept of Mix design-variables in proportioning-Mix design methods-Mix design procedure I.S.code method-Mix design by I.S.code Method only- Mix proportions for weighing batching and volume batching.

2.2 Pre-stressed concrete

General principle of pre stressing - advantages of pre stressed Concrete - Need for High strength steel and concrete-terminology- tendon-anchorage-pre tensioning-post tensioning-bonded prestressed concrete- non bonded prestressed concrete-methods of pre stressing - pretension method - post tension method – system of pre stressing - freyssinet system - Magnet blaton system - Lee-mc, call system - application of prestressing elements- concrete floor slabs – grid floor slabs-bridge girders- concrete pipes- concrete poles-prestressed concrete bridges.

UNIT- 3

14 Hrs

3.1 Fire Safety Installation

Causes of fire in buildings – Safety regulations – NBC – Planning considerations in buildings like non-combustible materials, construction, staircases and lift lobbies, fire escapes and A.C. systems. Special features required for physically handicapped and elderly in building types – Heat and smoke detectors – Fire alarm system, snorkel ladder – Fire lighting pump and water storage – Dry and wet risers – Automatic sprinklers - Exit requirements as per NBC of India.

3.2 Earth Quake – Proof Construction

Indian seismicity – Earthquake History- Causes of earthquake-changes in earth crust during earthquake- Technical terms related with earthquake such as focus, epifocus/epicenter, magnitude, intensity and seismograph- factors affecting damage- Seismic forces - Effect of seismic forces on Buildings -consideration of earthquake forces in design-general construction aspects- Planning of Earth quake resistant Buildings - Roofs and Floors- Articulation joints – Expansion Joints – I.S. code provision – Alterations to Buildings -precautions to be taken during occurrence of an earthquake– Foundation – Seismic coefficient for different zones.

UNIT – 4

13 Hrs

4.1 Deep Excavation

Definition-Problems encountered in deep excavations-Methods of Timbering-stay bracing, Box sheeting, vertical sheeting, runners and sheet piling-Precaution to be taken

during timbering-Dewatering of the foundation trenches-Methods –Pumping, Provision of sumps and side drain cement grouting, freezing process, electro-osmosis process.

4.1 Pile foundations

Definition – uses of piles – types of piles – bearing piles and Friction piles - classification based on material - cement concrete piles - cast-in situ-Pile - pre cast piles - description, advantages and disadvantages - load bearing piles Purpose - sheet piles types description - choice of type of pile - factors to be considered –pile cap and shoe – description - load test on piles – description - Pile driving –equipments - causes of failure of piles.

UNIT – 5

13 Hrs

5.1 Defects and Rehabilitation in Buildings

Prevention of defects in Buildings- Major causes of defects in buildings-

Improper filling of sunken portion of Toilet – Improper laying of weathering course and tiles-remedial measure-methods of filling the sunken portion of toilet- type of damp proof materials(with market name) to be added with mortar – maintenance of slope in sunken portion towards the Exterior wall - Weathering course- preparation of roof surface before laying weathering course- materials used for weathering course- preparation of lime brick jelly concrete as per CPWD Specification- preparation of bael fruit (kudukkai) water-fixing slope towards rain water outlet- methods of laying weathering course-beating methods(in unison with wooden thappies stick)-preparation of mortar for laying tiles- selection and field testing of clay tiles-method of laying of tiles- pointing- mortar preparation for pointing – methods of making pointing- curing and checking the pointing and slope after laying tiles.

5.2 Cracks in Buildings

Cracks in general - horizontal crack in masonry and plaster - vertical cracks at the bearing R.C.C beams or pillars - transverse cracks in R.C.C slab and sunshade-causes and repairs-Cracks in concrete – Types- Intrinsic cracking- structural cracking – plastic cracks -thermal contraction cracks - sulphate attack cracks – alkali aggregate reaction cracks – shrinkage cracks – causes and remedies.

5.3 Repair techniques

Materials for repair- Epoxy adhesive – injection and mortars – Repair and strengthening of concrete structures by bonded steel plates. Demolition of buildings - safety aspects – general - precautions during demolitions.

Revision and Test**12 Hrs.****Reference :**

1. M.S. Shetty , "Concrete Technology", S.Chand & Co, New Delhi, 2004.
2. S.P.Arora and S.P.Bindra, "Fire Resistant Construction", Dhanpat Rai & sons, 1998.
3. Dr.Janardhanjha and Prof.Suresh kunar Sinha, " Earth quake Proof Building Construction", 2001.
4. National Building Code of India, Part-IV and VII – 2006.
5. Rai Mohan and Jai Singh.M.P, " Advances in Building Materials and Construction" CBRI Roorkee,
6. SP-23 (S&T) – Hand Book on concrete Mixes based on Indian standards.
7. Guha.R.K., "Maintenance and Repair of Buildings", New Central Book Agency(p) Ltd-Calcutta, 2002.

11072 b. ELEMENTS OF INTERIOR DESIGN

5 Hrs/Week

16 Weeks

80Hrs

UNIT – I

(14 Hours)

Introduction to interior design

- ◆ . History of Interior Design
- ◆ . Definition of interior design
- ◆ . Elements and Principles
- ◆ Interior design typologies – their function with activities, Example: Living, bedroom, kitchen,
office, reception, work station, executive showroom etc.
- ◆ Themes and Concepts
- ◆ Colour
- ◆ Anthropometrics details

UNIT – II

(14 Hours)

Elements of interior design – enclosing elements

Ceiling – Walls, flooring – Fenestrations - Openings doors and windows access – Corridor, staircase enclosing, fenestration and access elements their function, character aesthetic and psychological. Their composition in terms of scale proportion, texture, colour etc. with various method of treatment in terms of material and construction to express functional aesthetics and psychological effects.

UNIT – III Lighting

(14Hours)

- ◆ Study of interior lighting
- ◆ Artificial and natural lighting
- ◆ Requirement of light for specific purpose.
- ◆ Different types of lighting and their effects
- ◆ Locating lighting points in interiors and planning electrical layouts.

UNIT – IV

(13 Hours)

Finishes and decorative accessories

- ◆ Carpets
- ◆ Rugs
- ◆ Wall papers
- ◆ Valances

- ◆ Painting
- ◆ Murals
- ◆ Sculpture
- ◆ Plants
- ◆ Fountains
- ◆ Wall hanging
- ◆ Venetian blinds

UNIT – V

(13 Hours)

Furniture

- ◆ Study of relationship of furnitures to space human movements
- ◆ Furniture design as related to human comfort, functions
- ◆ Materials
- ◆ Methods of construction
- ◆ Innovations and design ideas
- ◆ Study on furniture for specific function of interior, like office furniture, residential furniture,
- ◆ display systems etc. cabinet, ward robes, curio shelves, room dividers

Revision and Tests

(12 Hours)

REFERENCE BOOKS:

- | | |
|---------------------------------------|----------------------|
| 1. Designing and decorating interiors | - David Van Dommalan |
| 2. National Building code of India | - B.I.S |
| 3. Time-saver standard building types | - Callendar |
| 4. Architectural graphic standards | - Ramsey & Sleeper |
| 5. Human Dimension & Interior space | - Julius Panero |
| 6. Interior Design Illustrated | - Frank D.K. Ching |

11054- CAD IN CIVIL ENGINEERING DRAWING PRACTICE –II

6 Hrs/Week

16 Weeks

96 Hrs

Objectives:

- Practice on Drawings to be drawn in the computer with the available software packages.
- Drawing practice on Public Health structures based on given specifications.
- Drawing practice on Bridge structures based on given specifications.
- List the various standards specified in the IS 456 – 2000 for Concrete and Reinforcement Detailing.
- Drawing practice on Structural Detailing of different R.C.C Elements based on given specifications.

Important Note:

For all the drawings, detailed specifications shall be given and students should draw rough sketch in the observation book based on the given specifications and then only they should prepare drawings in the computer. All the drawings should teach in the class room at least one hour for each drawing exercise.

Preparation of drawing using available Software Packages (AUTOCAD, Pro.E etc.)

Group 'A' (Ph Engineering Drawing)

24 Hrs

1. Infiltration gallery (with one infiltration well, one straight gallery pipe, one inspection well and one jack well).{Practice Only}
2. Rapid Sand Filter.
3. Septic Tank with dispersion Trench/ Soak pit.
- 4 Bio gas plant. (Floating type)
- 5 R.C.C square overhead tank supported by four columns.

Group 'B' (Bridge Drawing)

18 Hrs

1. R.C.C Slab Culvert with splayed wing walls.
2. Two span Pipe Culvert.
3. Two span Tee Beam Bridge with square returns.(Practice Only)
4. Road Over Bridge(Pile foundation, Pile Gap ,Column,
5. Pre cast Beams & Deck slab) – {Practice Only}

Group 'C'

(Structural Engineering Drawings With Bar Bending Schedule)
Hrs

42

Standards as per IS 456 – 2000 – Reinforcement requirement – Curtailment – Anchorage-
Cover - Development length – Minimum depth required – Joints – Slab to Beam – Beam to
Column.

- 1 Simply supported one-way slab.
- 2 Simply supported two-way slab.
- 3 Restrained two-way slab.
- 4 Singly reinforced beam./ Doubly reinforced beam.
- 5 Tee Beams supporting continuous slab (practice only).
- 6 Dog-legged staircase.
- 7 Lintel and Sunshade (practice only)\
- 8 R.C.C. Column with footings. (square)

Revision and test

12 Hrs

For all the drawings, Detailed specifications shall be given.

Designs are not to be included in the examinations.

The drawings must include Layout plans, full plan, sections, details of components, etc., as applicable to each topic.

There are three Groups of drawings that are to be taught.

Only one question will have to be answered by the students in the examination BY LOT out of the total 12 Questions.(Questions should prepare for all the 12 Exercises like Civil Engineering Drawing –II question paper ie. Detailed specifications only.)

The Exercises a, b, c, d & e are only practice AND NOT for Examination. But it should be practiced compulsorily in the classes.

The students should not be allowed to draw drawings by giving drawing directly either in the class or in the Exam.

Note : Suitable marks may be allotted in the end examination for preparation of rough drawing

(not to scale)based on specifications.

Reference Books:

1. T.T.T.I ,”Drawing manual “
2. Krishnamoorthy,” Structural Drawing and Detailing” ,S.Chand & Co, 1991.
3. I. S. 456 – 2000.
4. SP 34 : 1987 Handbook on Concrete Reinforcement and Detailing.

11055 - CONSTRUCTION LAB PRACTICE

6 Hours / Week

16 Weeks

96 Hours

Objectives:

- Prepare centre line plan and foundation plan for a building
- Setting out foundation in the field for spread footing & column footing for a building
- Arrangement of bricks using English bond for right angled corner, Tee junctions and Square pillars
- Determine Workability of concrete by Compacting factor & Slump cone tests
- Cast Concrete cubes and test for compressive strength
- Determine fineness modulus of fine and coarse aggregate
- Arrangement and pre- measurement of steel work for slab, beam, column and column footing
- Determine the bulking characteristics of the given sand
- Calculation of centering areas for roof slab, beam and column.

List of Exercises:

1. Prepare and developing a centre line plan and foundation plan for a given line plan of a building.
2. Setting out spread footing foundation in the field for a given line plan of a building.
3. Setting out column and footing foundation in the field for a given line plan of a building (Framed structure)
4. Arrangement of bricks using English bond in one brick thick wall and one and half brick thick for right angled corner junction.
5. Arrangement of bricks using English bond in one brick thick wall and one and half brick thick wall for Tee-junction
6. Arrangement bricks using English bond in one brick thick, one and half and two brick thick square pillars.
7. Practice on measuring every day temperature in the Laboratory by setting standard Temperature measuring Devices in the Laboratory and separate register to be maintained in the Laboratory for temperature records for future reference. (For Demonstration purpose but it is Compulsory).
8. Setting of seismograph in the Laboratory and demo on measuring methods of Earthquake. (For Demonstration purpose but it is Compulsory)
9. Demonstration and practice in painting, varnishing and polishing.
10. Determination of workability of concrete by Slump cone test.
11. Determination of workability of concrete by Compaction factor test.
12. Casting of concrete cube and compression test on concrete cube.
13. Determination of Fineness Modulus of fine aggregate sample and plot a particle size distribution curve and also find the effective size and uniformity co-efficient

14. Determination of Fineness Modulus of coarse aggregate sample and plot a particle size distribution curve and also find the effective size and uniformity co-efficient
15. Determination of bulking characteristics of the given sand sample.
16. Cutting, Hooking, cranking and arrangement of reinforcement
 - a) Beam
 - b) Lintel and Sunshade
 - c) Column and footing.
17. Calculation of areas centering of the following: (Given sketch)
 - a) Roof slab with Beam
 - b) Column
18. Measurement Book – Procedure for entering in measurement book
19. Entering measurement for building works

All the students should enter directly on measurement book and they should keep the entry for the following works independently in the measurement book including schedule rates for the respective work for the current year.

Exercise from existing buildings inside the campus and only single room for each student.

 - a) Measurement and abstract for flooring work
 - b) Measurement and abstract for Brick work
 - c) Measurement and abstract for colour washing
20. Pre – measurement for steel work

The following models should be prepared in the laboratory, students should take out measurement from the model, they should enter the measurement in the measurement book and the total quantity of steel required in kg for each item may be arrived.

 - a. One way slab-size – 2.0 m x 2.0 m

Main rod	- 8 mm dia. - 15 nos.
Distributor	- 6 mm dia - 12 nos.
 - b. Column and footing

Footing – size – 1.0 m x 1.0 m – 10 mm dia	5 nos. each direction
Column – size – 150 mm x 150 mm – 10 mm dia	4 nos.
 - c. Beam – size – 230 mm x 300 mm – Length – 2.0 m

Bottom rod – 12 mm	– 3 nos.
Top rod – 10 mm	– 2 nos.
Stirrups – 6 mm	– 14 nos.

11011 – ENGLISH COMMUNICATION PRACTICE
(SEPARATE SYLABUS AVAILABLE)

4Hours/week

16 weeks

64 Hours

11051-STRUCTURAL ENGINEERING

Model Question Paper - I

Duration : 3 Hrs

Max Mark : 75

- Note :**
- 1 Answer ALL QUESTIONS from **PART - A** each carrying 1Mark
 - 2 Answer ALL QUESTIONS from **PART - B** each carrying 3Marks
 - 3 Answer ALL QUESTIONS from **PART –C** choosing either a or b each carrying 10 Marks
 - 4 IS 456 – 2000, IS 800- 1984 , Steel tables and structural Engineering hand books are permitted.
 - 5 Assume suitable data wherever necessary.

PART – A (10 x 1 = 10)

1. What is the modular ratio for M_{20} grade concrete.?
2. Mention the types of limit state
3. Specify the code requirements of minimum and maximum area of steel reinforcement for Beam.
4. Write down the Bending moment coefficient for continuous beam in all position?
5. List the types of two way slab
6. List the types of stairs.
7. What is isolated footing ?
8. What is the purpose of providing transverse reinforcement for a column
9. Write down the permissible stresses in tension and bending for steel sections.
10. Write the formula for calculating the strength of joint in Lap welds.

PART – B (5 x 3 = 15)

11. What is meant by doubly reinforced section
12. Define Effective span and writ down the effective span for all the cases.
13. What are the classifications of slab. How to classify the slab
14. Draw a neat sketch of rectangular footing
15. Define gross area, net area of tension member.

PART –C (10 x 5 = 50)

16. a i) Draw the stress and strain diagram for working stress method.

ii) A RCC beam 300×420 mm effective depth is reinforced with 3 Nos of 16mm diameter bars, grades of materials are Fe415, and M_{20} . Determine the M.R. of the section by Limit state method

(OR)
- b. A simply supported beam of rectangular section 250 mm wide carrying a ultimate UDL of 50 Kn/mof effective span 6m . Design the section for flexure using Limit State method. Use M_{20} concrete and Fe 415steel.
17. a) Design a T-beam is simply supported at its both ends to carry a service live load of 20KN/m and superimposed dead load of 16KN/m over a clear span of 9m. The width and overall depth of the beam are kept as 360mm and 600mm respectively. Use M_{25} and Fe

415 grades.

(OR)

- b) Design the shear reinforcement of T- beam having the following data, Ultimate shear 100kn effective flange width 740mm. Breadth of rib – 240mm. Reinforcement 5 Nos
25 mm dia bars. Thickness of slab – 80 mm. Effective depth – 400 mm Steel grade Fe 415
Concrete grade M₂₀.

- 18.. a) Design a R.C slab for a room has a clear span of 3.75m thickness of walls supporting the slab is 300 mm. Imposed load on the floor may be taken as 2000 N/m² the weight of floor finish is 600 N/m². Design the floor slab of if M₂₀ concrete and Fe 415 steel are used. Check for shear is not necessary.

(OR)

- b) Design a simply supported roof slab for a watchmen cabin of clear size 2m×3m. the thickness of wall all-round is 200 mm. Access is not provided to the roof. The corners of the slab are not held down. Weight of weathering course will be 1 KN/m². Use M₂₀ grade concrete and Fe 415 steel.

19. a) Design a rectangular RC column of side ratio 1.5 to carry an axial load of 2000 KN. Take f_{ck} – 20 Mpa, f_y = 550Mpa. The unsupported length of the column is 4 m. the ends of the column are effectively held in position but not restrained against rotation. The lateral dimensions of the column not exceed 600mm.

(OR)

- b) Design a square footing of uniform thickness to carry an axial load of 1200 KN size of column is 400 mm × 400 mm safe bearing capacity of soil is 150 KN/m² use M₂₀ and Fe 415. Check for shear not required

20. a) Determine the maximum imposed load (UDL) that could be carried by an ISLB 400 @ 569 N/m. When simply supported at its ends with an effective span of 8m if f_y = 250 mpa and E = 2×10⁵ N/mm².

(OR)

- b) A Tee section ISHT 150 @ 294 N/m is used as a tension member its flange is connected to gusset plate of 12mm thickness by welding. Its web is connected to gusset plate of 12 mm thickness by welding. Yield strength of steel used is 300m pa. Determine the maximum tensile strength of the member.

11051- Structural Engineering Model-II

Model Question Paper - II

Duration : 3 Hrs

Max Mark : 75

- Note :**
- 1 Answer ALL QUESTIONS from **PART - A** each carrying 1Mark
 - 2 Answer ALL QUESTIONS from **PART - B** each carrying 3Marks
 - 3 Answer ALL QUESTIONS from **PART -C** choosing either a or b each carrying 10 Marks
 - 4 IS 456 – 2000, IS 800- 1984 , Steel tables and structural Engineering hand books are permitted.
 - 5 Assume suitable data wherever necessary.

PART – A (10 x 1 = 10)

1. What is neutral axis.
2. Draw stress block in Limit state Flexure.
3. Write down span depth ration for cantilever beam and simply supported beam
4. Write down the effective flange width of T-bam.
5. What is torsional reinforcement in slab.
6. Write down the effective width of stairs landing parallel to stair.
7. Explain helical reinforcement in columns.
8. Write down the minimum thickness required for sloped footing as per IS-456.
9. List any two compression members with sketches.
10. Draw beam to beam welded connections.

PART – B (5 x 3 = 15)

11. Write down the assumptions made in limit state of collapse in flexure.
12. How the effective span of simply supported beams or slabs are determined. and Specify nominal cover and minimum cover reinforcement as per IS 456 – 2000.
11. What is difference between one way slab and two way slab? and What are the functions of distribution bars in slabs.?
12. What are the assumptions made in the design of columns by limit state method.?
13. What are the classifications of beams.? and Describe welded connections.

PART – C (5 x 10 = 50)

14. a. A singly reinforced rectangular beam 350mm wide has a span of 6.25m and carries an working load (UDL) of 30 KN/m Find the effective depth and the area of the tensile reinforcement. Use M20 concrete and Fe415 steel. Use Limit state method.
(OR)
 - b. i. A beam 230 mm wide and 400 mm effective depth is reinforced with 3 Nos of 16 mm dia mild steel bars in tension. Compute the flexural capacities for M₂₀ mix.
 - ii. Write down the spacing of main reinforcement and side face reinforcement as per IS-456.
15. a. A simply supported T- beam is to be provided over the clear span of 12m to carry an UDL of 20 KN/m excluding the self weight. Design the midspan section use M₂₀ concrete and Fe 415 steel in tension for the limit state of collapse. Assume the width of support as 300 mm.
(OR)
 - b. i. A beam with rib width 230mm and effective depth 500 mm is reinforced with four numbers of 20 mm dia bars as tension reinforcement. The material used are M15

grade and Fe 415 steel reinforcement. Design the shear reinforcement and draw the neat sketch.

ii. Draw the different types of shear reinforcement.

16. a. Design a reinforced concrete slab simply supported on masonry walls 3.8m apart with M_{20} mix and Fe 415 steel by limit state method. Imposed load (not fixed) 2 KN/m^2 floor

finish load is 0.6 KN/m^2 bearing on each end is 200 mm.

(OR)

b. i. List the types of stairs explain any one type of stair, with a neat sketch -5

ii. The vertical height between two successive floor of a multi storeyed residential building is 3m the clear size if the staircase roof is $2.10 \text{ m} \times 4.25 \text{ m}$. plan a dog logged stair case of the building. -5

17. a. Design a short square column using M_{15} concrete and mild steel carry an axial load of 800KN. by limit state method.

(OR)

b. i. List the types of footing. Explain any one type of footing with a neat sketch. -5

ii. Briefly explain with sketches i) critical section for bending moment and shear for a column for a footing. -5

18. a. Two channels ISMC 300 @ 331 N/m are placed back to back at a clear distance of 100 mm. If the effective length of the member is 4 m. Find the safe bearing capacity of the column.

(OR)

b. The longer leg of an unequal angle ISA $125 \times 75 \times 8 \text{ mm}$ is to be connected to a gusset

20KN. plate by fillet welds along its sides only. The angles carry an axial tension of

permissible Centroidal distance (C_{xx}) of the angle is 41.5 mm. Design the joint if the

shear stress in the used is 108 Mpa .

11052 – QUANTITY SURVEYING

MODEL QUESTION PAPER - I

Duration : 3 Hrs

Max Mark : 75

- Note :** 1 Answer ALL QUESTIONS from **PART - A** each carrying 1Mark
2 Answer ALL QUESTIONS from **PART - B** each carrying 3Marks
3 Answer ALL QUESTIONS from **PART –C** choosing either a or b each carrying 10 Marks

PART-A (10X1 = 10)

1. What are the categories of specification?
2. What is meant by out turn of works.?
3. What are the systems adopted for taking quantities?
4. Plastering with C.M. 1:3, 12mm thick – Rate per 10m²
5. Define Group system.
6. Mention the painting co-efficients for the following items of work
i) paneled door, ii)collapsible door.
7. Write the abbreviations for the following :
1.) C & P 2.) b.o.e.
8. Prepare the detailed estimate for 15cm thick R.C.C. slab of room size 3m x 4m.
9. Define valuation.
10. Define Gross and Net Income

PART – B (5 x 3 =15)

11. What are the different types of estimates and define plinth area method of estimate.
12. Prepare the data for plastering 1:4, 12mm thick.
13. Write down the function of Abstract and explain the method of writing Bill.
14. Prepare the detailed estimate for septic tank of size 4mx3m and depth 4m using 230mm thick brick wall all around and 115mm thick R.C.C baffle wall and middle.
15. A building of 100 m² is in a plot of land 250m² area. The construction cost is Rs.6,000/- per sq.m. and land cost is Rs.2,500/sq.m. The age of the building is 20 years and life of the building is 100 years. Find the value of the property.

PART – C. (5 x 10 = 50)

- 16.(a) The actual cost of a single story residential building of plinth area 85m² is found to be Rs.4,67,500/- in which 70% is towards the cost of materials and 30% towards the labour. It is proposed to construct a similar building of same specification with a plinth area of 125m² at a place where the cost of materials to be 15% more and cost of labour 20% less. Estimate the rough cost of the proposed building.

Or

- (b) i. Write a detailed specification for cement concrete 1:4:8 for foundation using 40mm size aggregates.
- ii. Work out all the materials required for stucco plastering 12mm thick using granite chips –

250m².

Materials required:

0.15m³ C.M. 1:5

0.15m blue granite chips

86.50 kg. Cement.

17. (a) Prepare the data for Brick work in C.M. 1:5 using II class bricks for foundation – rate per 1m^3 .

Or

- (b) i. Prepare the data for Honey Comb work using I class bricks in C.M. 1:4, and plastered with C.M. 1:4 – 10m^2 .
 ii. Flooring with cuddapah slabs 50mm thick over a bed of concrete 100mm thick (1:4:10) and pointed with C.M. 1:3 – 1m^2 .

Plastering with C.M. 1:3, 12mm thick – 10m^2

C.M. 1:3	-	0.14m^3
Mason I Class	-	2 Nos.
Mazdoor grade I	-	1 No.
Mazdoor grade II	-	1 No.

Brick Work in C.M. 1:5, using II class Bricks – 10m^2

Bricks (19 cm x 9 cm x 5.70 cm)	-	7500 Nos.
C.M. 1:5	-	2.70m^3
Mason I Class	-	3.50 Nos.
Mason II Class	-	7.10 Nos.
Mazdoor gr.I	-	7.10 Nos.
Nazdoor gr.II	-	14.10 Nos.

Flooring with cuddapah slab 50mm thick over a bed of concrete 100mm thick – 10m^2

50mm thick cuddapah slab	-	10.50m^2
Lime mortar 1:2	-	0.12m^3
Cement Concrete 1:4:10	-	1m^3
Pointing with C.M. 1:3	-	10m^3
Mason I class	-	1.10 Nos.
Mason II class	-	3.20 Nos.
Mazdoor gr.I	-	2.2 Nos.

Lime mortar 1:2 – m^3

1m^3	-	sand
0.50m^3	-	lime
1m^3	-	grinding charges.

Pointing with C.M. 1:3 – 10m^2

0.04m^3	-	C.M. 1:3
2.2 Nos.	-	Mason II class
0.5 Nos.	-	Mazdoor gr.I
1.10 Nos.	-	Mazdoor gr.II

Honey Comb work using grade 7.5 brick in C.M. 1:4 and plastered with C.M. 1:4 – 10m^2

Grade 7.5 bricks	-	720 Nos.
C.M. 1:4	-	0.70m^3
Mason I class	-	3.20 Nos.
Mason II class	-	6.5 Nos.
Mazdoor I class	-	2.2 Nos.
Mazdoor II class	-	5.4 Nos.

Cost of Materials at site

Broken stone 20mm size	-	$475/\text{m}^3$
------------------------	---	------------------

Sand	-	185/m ³
Cement	-	3065/ 1 tonne
Steel	-	15200/ 1 tonne
A.C. sheet	-	123/m ³
Bricks (1/9 x 9 x 5.7 cm)	-	1500/1000Nos.
Shell lime screened	-	850/m ³
50mm thick cuddapah slab	-	220/m ²
lime store	-	450/m ³
Grade 7.50 bricks	-	4000/1000 Nos.

Cost of labour

Filter II class	-	120/Each/day
Carpenter I class	-	140/Each/day
Mason I class	-	160/Each/day
Mason II class	-	140/Each/day
Mazdoor gr.I	-	90/Each/day
Mazdoor gr.II	-	60/Each/day
Centering charges	-	80/m ²
Mixing charges for mortar	-	60/m ³
Grinding charges	-	30/m ³

18. (a) i. Taking of quantities using group system, - Earth work excavation in foundation.
ii. What are the qualities of a quantity surveyor.

Or

- (b) Explain with example, how will you prepare the abstract?

19. (a) i. Prepare a detailed Estimate quantities for the following items for a septic tank with soak

pit

- ii. B.W. in C.M. 1:4 in septic tank.

Or

- (b) i. Plastering with C.M. 1:3 for all exposed surfaces.
ii. Earth work excavation for septic tank and soak pit.

- 20 (a) i. A building of 120 m² is in a plot of land 300m² area. The construction cost is Rs.8,000/- per sq.m. and land cost is Rs.3,500/sq.m. The age of the building is 20 years and life of the building is 100years. Find the value of the property.

- ii. A flat was purchased for Rs.7,00,000/-. Net return from the property is 10% of cost of purchase and repair charges, sinking fund and other charges for 4% of the flat cost.

If

the municipal tax etc. is 40% of the gross rent. Find the monthly rent for the flat.

Or

- (b). The cost of the building at present market rate is Rs.4,00,000/-. The age of the building is 20 years. The building is of R.C.C. with teak wood doors and windows. The building is constructed on a plot of land of 150 m², cost of land in the locality is Rs.450/m². The present value of sanitary, water supply and electrical arrangement works out to Rs.40,000/-. Allow a depreciation of 1% on teak wood and R.C.C.

11052 – QUANTITY SURVEYING

MODEL QUESTION PAPER-II

Duration : 3 Hrs

Max Mark : 75

- Note :**
- 1 Answer ALL QUESTIONS from **PART - A** each carrying 1Mark
 - 2 Answer ALL QUESTIONS from **PART - B** each carrying 3Marks
 - 3 Answer ALL QUESTIONS from **PART - C** choosing either a or b each carrying 10 Marks

PART – A (5 x 1 = 5)

1. Mention the out turn of a mason for the following works
 - (1) Cement concrete in foundation
 - (2) Plastering B.W. in C.M. 12mm thick.
2. What are the points to be considered while writing a report.
3. Define schedule of rates
4. Prepare the detailed estimate for out side white washing for a building of size 30m x40m and height 4m. openings need not be considered.
5. Mention the two systems adopted in taking of quantities in quantity surveying.
6. What are the items Lump sum provision made in the estimate.
7. Define Trade system.
8. Calculate the total quantity of bitumen required for surface dressing – 10m²,
9. Define Book value.
10. Define Year's Purchase.

PART – B (5 x 3 = 15)

11. When the revised estimate is prepared and Give the types of approximate estimation.
12. Work out the materials required for cement mortar 1.3 C.M. 1:3 – m².
13. With an example explain the squaring dimension.
14. State the procedure of long wall and short wall method of detailed estimate.
15. What are the different factors to be considered while valuing a property? Mention any Two factors which will affect the market value of the property.

PART – C. (5 x 10 = 50)

- 16.(a) The actual expenditure incurred in the construction of a hostel building accommodating 300 students Rs.33,30,000/-. Now it is proposed to construct another similar building in the same complex to accommodate 180 students. Estimate approximately the probable expenditure assuming the variation in the cost of the materials and labour as 30%.

Or
- (b) i. Write a standard specification for surface dressing over existing water bound Macadam Road.
 - ii. Write a report to accompanying an estimate for a village water supply scheme.
- 17.(a) Prepare a data for laying wearing coat with pre coated metal 12mm size using 5.10m³ metal for 10m² over the existing bitumen surface at the rate of 44kg. Of bitumen 80/100 grade per 1m³ of metal for premixing and 50 kg. Of 80/100 grade bitumen per 100m² for tack coat including consolidation with power roller rolling. The rate includes hire charges for tools and plants – 10m².

Or

(b) i. R.C.C. floor slab 125mm thick including cost of reinforcement, centering etc. complete
– 10m².

ii. Flooring with C.C. 1:4:8, 100mm thick and top plastered with C.M. 1:4, 20mm thick - 10m².

C.C. 1:2:4 – for RCC works – 10m³.

Broken Stone 20mm	-	9m ³
Sand	-	4.50m ³
Cement	-	3231 kg.
Mason II Class	-	3.50 Nos.
Mazdoor I Class	-	21.20 Nos.
Mazdoor II Class	-	35.30 Nos.

R.C.C. floor slab 125mm thick - 10m²

C.C. 1:2:4	-	As required
Reinforcement	-	100 kg./m ³ of concrete
Binding wire	-	1% of steel
Fabricating and placing of steel	-	as required
Centering & shuttering	-	as required

(Add 10% extra for sides)

C.C. 1:4:8 – 10m³

Broken stone 40mm	-	9.50m ³
C.M. 1:4	-	3.80m ³
Mason II Class	-	1.80 Nos.
Mazdoor I Class	-	17.70 Nos.
Mazdoor II Class	-	14.10 Nos.

Plastering with C.M. 1:4, 20mm thick – 10m²

Cement Mortar 1:4	-	0.21m ³
Mason I Class	-	1.6 Nos.
Mazdoor grade I	-	2.20 No.
Mazdoor grade II	-	1.10 Nos.

Flooring with C.C. 1:4:8 100mm thick and top plastered with C.M. 1:4, 20mm thick – 10m²

Cement Concrete 1:4:8	-	1 m ³
Plastering with CM 1:4, 20mm thick	-	10m ²
Mason I class	-	1 No.
Mason II class	-	1 No.

Laying wearing coat with precoated metal 12mm size – 10m²

IRC 12mm chips	-	as required
Bitumen	-	as required
Kerosene	-	Rs.20/10m ²
Labour charges	-	Rs.150/m ²

Hire charges for tools and plants – LS.

Cost of materials at site:

Cement	-	3500.tonee
Sand	-	225/m ³

Broken stone 20mm	-	525/m ³
Broken stone 40mm	-	375/m ³
Steel reinforcement	-	18000/Tonne
Binding wire	-	30/kg.
IRC 12mm	-	Rs.160/m ³
Bitumen 80/100 grade	-	Rs.4500/1 tonne

Cost of Labour:

Mason I Class	-	170/Each/day
Mason II Class	-	150/Each/day
Mazdoor I Class	-	100/Each/day
Mazdoor II Class	-	70/Each/day
Mixing charges	-	50/m ³
Centering charges	-	120/m ²
Steel fabrication	-	200/100 kg.

18. (a) Taking of quantities using group system, - sand filling in basement.
Or
- (b) i. What are the points to be remembered in entering dimension paper.
(c) ii. Briefly explain the checking the bill.
19. a. Take out the quantities for the following items for "A R.C.C. slab culvert".
i Cement concrete 1:4:8, for foundation for all walls.
ii B.W. in C.M. 1:5, for sub structure only.
Or
- b. Pointing with C.M. 1:2, for the exposed faces of walls.
20. a). What are the purpose of valuation? and explain the various methods for calculating the depreciation.
Or
- (b) i. A flat was purchased by Rs.5,00,000/-. Net return from the property is 15% of cost of purchase and the repair charges, sinking fund and other charges are 8% of the flat cost. If the municipal tax etc. is 30% of the gross rent, Find out the monthly rent for the flat.
- ii. The built up portion of a I Class building on 400m² land, near a city is 250m². The plinth area rate in the neighbourhood including water supply, sanitary and electrification charges is Rs.4500/m². The age of the building may be taken as 20 years. The cost of land in the locality is Rs.900/m². Assuming suitable rate of depreciation, calculate the present value of the property.

11071.a CONCRETE TECHNOLOGY AND ADVANCED CONSTRUCTION
(ELECTIVE THEORY –I)

MODEL QUESTION PAPER- I

Max Mark : 75

Duration : 3 Hrs

- Note :** 1 Answer ALL QUESTIONS from **PART - A** each carrying 1Mark
2 Answer ALL QUESTIONS from **PART - B** each carrying 3Marks
3 Answer ALL QUESTIONS from **PART - C** choosing either a or b
each carrying 10 Marks

PART -A (10X1=10)

1. What are the factors affecting workability.
2. Define admixtures.
3. What are the methods available for mix design
4. Define Tendon
5. Define epicenter.
6. Define the following terms (i) focus (ii) seismic coefficient
7. Classify the piles based on materials.
8. When is sheet piling adopted?
9. Define shrinkage cracks.
10. What are the factors which influences the cracks?

PART-B (5 x 3 = 15)

11. Write short notes on curing of concrete.
12. What are the advantages of pre stressed concrete?
13. Write short notes on "Intensity of earth quake"
14. What are the problems encountered in deep excavations.
15. Name the damp proof materials with brand name available in the market.
And Write short notes on "Patch repairs for plastering".

PART-C (5 x 10 = 50)

16. a. i. Explain the steps involved in preparation of concrete
ii. Explain the following (i) Ferro cement (ii) Fiber reinforced concrete
or
b. i. What are the composition of cement.
ii Explain i. Light Weight concrete ii. Polymer concrete.
17. a. i. Write the procedure of Mix design by I.S.Code method.
ii. Explain with a neat sketch Freyssinet system of prestressing.
Or
b. i. Define weigh batching and volume batchiong.
ii. Draw the different applications of precast elements.
18. a. i. Write short notes on Fire-resistance of concrete.
ii. What are the general guidelines for planning of earthquake resistant
buildings?
Or
b. i. What are the Exit requirement as per NBC of India.
ii. What are the precautions to be taken during Earth quake.
19. a. i. Describe the method of freezing process for dewatering the foundation

trenches with a neat sketch.

- ii. Describe a process of casting a precast concrete pile and draw a neat sketch of a typical concrete pile.

Or

- b.
 - i. What are the problems encountered during deep excavation.
 - ii. What are the advantages and disadvantages of pile foundation.

20.
 - a.
 - i. What are the materials required for weathering course and explain
 - ii. How to prepare the lime concrete for weathering course.

Or

- b. Explain the methods of repairing cracks in concrete.

1071.a CONCRETE TECHNOLOGY AND ADVANCED CONSTRUCTION
(ELECTIVE THEORY –I)

MODEL QUESTION PAPER-II

Max Mark : 75

Duration : 3 Hrs

- Note :** 1 Answer ALL QUESTIONS from **PART - A** each carrying 1Mark
2 Answer ALL QUESTIONS from **PART - B** each carrying 3Marks
3 Answer ALL QUESTIONS from **PART - C** choosing either a or b each carrying 10 Marks

PART – A (10x1=10)

1. What are the different types of cements.
2. Define segregation and bleeding of concrete.
3. What is Mix design.
4. Define pretension
5. Explain seismograph.
6. What are the causes of Earth quake.
7. What are the methods available for dewatering the foundation trenches.
8. What are the uses of piles.
9. What are the major causes for defects in building.
10. What are the materials used for repairs in buildings.

PART – B (5x3=15)

11. Explain (i) Light weight concrete (ii) self compacting concrete
12. Explain the need of High strength concrete and steel in prestressing.
13. What are the effects of seismic forces in Buildings.
14. Explain cement grouting. and What are factors to be considered during piling.
15. Define structural cracking in concrete and What are the factors to be considered during demolition.

PART – C (5 x 10 = 50)

16. a. i. Explain weigh batching and volume batching.
ii. Explain special concrete and its applications.
Or
b. i. What are the I.S.Code provisions for aggregates used for concrete.
ii. Explain the process of manufacturing concrete.
17. a. Design the Mix design for the given parameter by I.S.Code Method.
Or
b. i. Draw neat sketch of prestressing floor slab, grid floor , circular pipes.
ii. What are the methods available for post tensioning and Explain any one of them.
18. a. i. Explain the I.S.code provision for Earthquake in Buildings.
ii. Write short notes on fire resisting building materials.
Or
b. i. What are the causes of Earthquake.
ii. What are the special features required for physically challenged and elderly peoples in a building.
19. a. i. What are the precaution to be taken during timbering
ii. Describe the method of electro-osmosis process for dewatering the foundation trenches.

Or

- b. Explain the procedure adopted for load test on pile.
20. a. i. How to repair the plastering cracks in buildings.
ii. Explain the detailed procedure for laying weathering course and tiles.
- Or
- b. Explain the strengthening the concrete structures by bonded steel plates.

1072.b. ELEMENTS OF INTERIOR DESIGN

Model Question Paper-I

Max Mark : 75

Duration : 3

Hrs

- Note :** 1 Answer ALL QUESTIONS from **PART - A** each carrying 1Mark
2 Answer ALL QUESTIONS from **PART - B** each carrying 3Marks
3 Answer ALL QUESTIONS from **PART - C** choosing either a or b
each carrying 10 Marks

PART – A (10x1=10)

1. _____ is the shape comprising four sides conjoining at right angles.
2. Repetition of particular design or motif termed as _____ architecture.
3. Give an example of resilient flooring material.
4. Sill level of window should be _____ meters.
5. Give an example of diffuser used in diffused lighting.
6. Give the value of illumination required for a bedroom.
7. Give one example of wall covering
8. What is a mural painting?
9. What is a partition?
10. What is modular function?

PART – B (5x3 =15)

11. Explain the purpose of interior design
12. What type of flooring is selected for a dining room in a residence?
13. Explain what type of lighting is done in drawing studio
14. What are the functional values of carpets and rugs?
15. What are the various furniture used in a living room

PART – C (5x10 =50)

16. a. Explain about the principles of design
Or
b. Define anthropometrics in design
17. a. Explain the basis and functional requirement of a staircase
Or
b. Explain various methods of construction in order to obtain certain Psychological effects

18 .a. Explain about different types of lighting and their effects.

Or

b. Differentiate artificial and natural lighting

19. a. State the advantage and disadvantage of using plants in the interior.

Or

b. Define wall paneling and what are its uses.

20. a. How will you use decorative furniture in a weekend two-bed room cottage?
Explain.

Or

b. What are decorative furniture's? Where they are used?

1072.b. ELEMENTS OF INTERIOR DESIGN

MODEL QUESTION PAPER- II

Max Mark : 75

Duration : 3

Hrs

- Note :** 1 Answer ALL QUESTIONS from **PART - A** each carrying 1Mark
2 Answer ALL QUESTIONS from **PART - B** each carrying 3Marks
3 Answer ALL QUESTIONS from **PART - C** choosing either a or b
each carrying 10 Marks

PART – A (10x1=10)

1. _____ is the visible trace of moving point.
2. _____ is a science of the relationship with the things objects and space
3. Give an example of non resilient flooring material
4. Height of the window should be _____ meters and above
5. In _____ lighting the fitting s are hidden so the only lighting is only seen.
6. Give the volume of illumination required for a library reading
7. What is wall papering
8. What is Venetian blind
9. What is a upholstery
10. What is a partition wall

PART – B (5x3=15)

11. Explain the objectives of interior design
12. State briefly how colour play an important role in interior design
13. What are he methods of artificial lighting? Explain any one of them
14. Explain how wall paper is used in interior
15. List any five important points to be considered while selecting a furniture

PART – C (5x10= 50)

16.a. Briefly explain how the principle of design are used in the interior design

- Or
- b. What is the role-played by colours in the design of interiors? Mention any two popular colour schemes
- 17.a. State briefly how texture and scale play an important role in interior design
Or
b. Explain the basic and functional requirement of doors and window openings
- 18 .a. Explain the general requirements of natural and artificial lighting.
Or
b. Design and explain what type of lighting done in a living room
- 19 a. State and explain various methods of carpeting the room
.Or
b. Design a fountain for a five star hotel reception.
20. a. Explain the furniture arrangement for a living room and an office
Or
b. Sketch the layout of a bedroom indicating the furniture arrangement?

VI-SEMESTER

11061 – CONSTRUCTION MANAGEMENT WITH MIS

**7 Hours/Week
Hours**

16 Weeks

112

OBJECTIVES:

- Describe the Role of government and construction agencies
- Describe the organization set up of PWD
- Mention the construction activity and fixing the construction agency.
- Describe the aspects of inspection and quality control methods
- Describe the banking system.
- Feasibility study of a project
- Planning for civil engineering project
- Significance of CPM and PERT Techniques.
- Describe the types of contract system
- Study organization chart of a construction company.
- Concepts and requirement of Entrepreneurship
- Describe the construction automation and robotics
- Computation of Net present value method

**UNIT – 1
Hours**

20

Construction sector in india:

Construction and national development - role of government and construction agencies - Types of construction - public and private - construction practice - the owner – consultant – contractor- duties and responsibilities - various stages in construction of a project.

Project feasibility report:

Technical / Financial / Economic / Ecological Analysis - flow diagram for feasibility study of a project.

Planing for civil engineering project:

Objectives of planning - its advantage to client and engineer – limitations -stages of planning by owner & contractor.

Contract management:

Types of contract - contract documents - possible contractual obligations - meaning of specification - tender notice – types - tender documents - earnest money deposit (EMD) and security deposits (SD) - scrutiny and acceptance of a tender - contract agreement – contractual changes and termination of contract – subcontract - rights and duties of sub contractor.

**UNIT-2
Hours****20****Construction organisation and superintendence***

Forms of business organizations - sole proprietorship – partnership - joint stock company - Co-operative society - state enterprise- delegation of responsibility, personnel requirement and division of work – decentralization - construction supervision and superintendence - pay rolls and records - purchase and delivery of construction material and equipment - percentage completion report - insurance record - project office requirement - organisation chart of a small / medium / large construction company (broad outline only).

(*The objective is to make the student to understand the private sector in construction industry)

Human factors in construction:

Quality of efficient construction managers – personality - ethics and integrity - personal drive- multidisciplinary capability - human relations

Departmental procedure and accounting (basic treatment only)

Organisation of P.W.D. - responsibilities of officers - accounting procedure (administrative sanctions, technical sanctions, payment of bills) - imprest & temporary accounts –cash book - works register - accounting for consumable materials - record for tools and plants - importance of M-book and its entries – work charged establishment – nominal muster roll (N.M.R) – daily labour reports (D.L.R)

**UNIT- 3
Hours****20****Scheduling and time management:**

Scheduling – definition – its preparation – uses and advantages – classification – methods of scheduling – bar chart – job layout – Gantt chart – work breakdown chart(WBC) – network for

projects management – Activity – Event – Dummies – basic assumptions in creating a network – rules for drawing networks – Fulckerson’s rule for numbering the events - critical path method –

ES, EF, LS, LF, Floats – significance of critical path – PERT – time estimates – earliest expected time – latest allowable occurrence time – slack. Standard deviation variance – Simple problems.

Resource management

Definition – need for resource management – optimum utilization of resources- finance, materials, machinery, human resources - resources planning – resource levelling and it’s objectives” - Time – cost trade off – crashing – need for crashing an activity – methods & tips for crashing – time Vs cost optimization curve – cost slope – its significance in crashing.

A simple problem (like a case study, but not for the examination) can be solved in class room for better understanding of the resource levelling and during and duration cost trade - off.

UNIT-4

20 Hours

Quality management and safety

Importance of quality – elements of quality – quality assurance techniques (inspection, testing, sampling) importance of safety – causes of accidents – role of various parties (designer / employer / worker) in safety management – benefits – approaches to move safety in construction.

Construction distibutes and thier settlement

Introduction – development in disputes – categories of disputes – modes of settlements - Arbitration

Construction labour and legistation

Need for legislation - Payment of wages Act - Factories Act – Contract labour (Regulation and abolition Act – Employees Provident Fund (EPF) Act.

Entrepreneurship

Definition – Role and Significance – Risks and Rewards – Concepts of Entrepreneurship -Profile and requirement of entrepreneur - Programmes existing in India – SISI, DIC, SIDCO – Funding and technical assistance to Entrepreneurship.

UNIT-5

20

Hours

Information management and computers

Introduction – definition of MIS – Out lines of MIS – Use of computers in fields of construction industry – requirements of MIS – A data base approach – definition –Benefits - a data base approach to contractor's account and its advantage – basic concepts of estimation - Project management and operations simulation packages – construction automation and robotics.

Financial management

Elements of cash flow – time value of money – Interest rate of capital – Present value computation - NPV method – IRR method – simple problems - Global banking culture - types of banks – their activities – corporate banks – personal, retail and rural banking – treasury management.

TEST & REVISIONS -

12 Hours

Reference Books

- 1.Sengupta.B, & H.Guha. "Construction Management and Planning ", Tata McGraw Hill Publishing Company Ltd., New Delhi.
- 2.Seetharaman. S, " Construction Engineering & Management ", Umesh Publications, Nai Sarak, New Delhi.
- 3.Boyd.C. & Paulson Jr, "Computer Applications in Construction ", Tata McGraw Hill Publishing Company Ltd., New Delhi, 1995
- 4.Sanga Reddy. S, "Construction Management", Kumaran Publications, Coimbatore.
- 5.Rangwala.S.C., "Construction of Structures and Management of Works", Charotar Publishing House, Anand-388001, 3rd Edition, 2000.

11062 - HYDRAULICS

7 Hrs/Week

16 Weeks

112 Hours

Objectives :

- Define Properties of fluids and its Physical quantities.
- List different types of pressure and various pressure measuring devices.
- Calculate hydrostatic forces on plane surfaces immersed in water.
- Explain types of forces, energy and application of Bernoulli's theorem.
- Describe different types of Orifices, Mouthpieces, Discharge formulas and their practical applications.
- State different Losses of flowing liquid in Pipes and their equations.
- Describe different types of Notches, Weirs, Discharge formulas and their practical applications.
- Describe different types of Channels, Discharge formulas and condition for maximum discharge.
- Explain the procedure of Canal Linings.
- Explain the construction details, specifications and efficiency of Reciprocating Pumps and Centrifugal Pump.
- Solve Simple problems connected with the subject.

UNIT – 1.

20 Hours

1.1 Introduction:

Hydraulics – Definition - Properties of fluids - Mass, force, weight, specific volume, specific gravity, specific weight, density, relative density, compressibility, viscosity, cohesion, adhesion, capillarity and surface tension -Dimensions and Units for area, volume, specific volume, velocity, acceleration, density, discharge, force, pressure and power.

1.2 Measurement of Pressure:

Pressure of liquid at a point – Intensity of pressure - Pressure head of liquid - Conversion from intensity of pressure to pressure head and vice-versa - Formula and Simple problems. Types of pressure - Static pressure, Atmospheric pressure, Gauge pressure, Vacuum pressure and Absolute pressure – Simple problems. Measurement of pressure - Simple mercury barometer- Pressure measuring devices- Piezometer tube - Simple U-tube manometer- Differential manometer – Micrometer - Problems.

1.3 Hydrostatic Pressure on Surfaces:

Pressure on plane surfaces - Horizontal, vertical and inclined surfaces-Total pressure - Centre of pressure - Depth of centre of pressure - Resultant pressure - Problems. Practical application - Sluice gates, Lock gates and Dams– Simple problems.

UNIT - 2

20 Hours

2.1 Flow of fluids:

Types of flow –Laminar and turbulent flow - Steady and unsteady flow –Uniform and Non-uniform flow - Equation for continuity of flow (law of conservation of mass) .

Energy possessed by a fluid body - Potential energy and Potential Head -Pressure energy and Pressure Head - Kinetic Energy and Kinetic Head - Total Energy and Total Head – Bernoulli's theorem- Statement only - Problems. Practical applications of Bernoulli's theorem –Venturimeter - Orificemeter (Derivation not necessary)- Simple problems.

2.2 Flow through orifices and mouthpieces:

Definitions- Types of orifices - Vena Contracta and its Significance - Hydraulic coefficients C_d , C_v and C_c - Formula - Simple problems - Large orifice – Definition – Discharge formula – Simple problems - Practical applications of orifices. Mouthpieces- Types- External and Internal Mouthpieces - Discharge formula - Simple problems.

2.3 Flow through pipes :

Definition of pipe-Losses in pipes – Major losses - Minor losses - Sudden enlargement, sudden contraction, obstruction in pipes(no proof) - Simple problems - Energy/Head losses of flowing fluid due to friction losses - Darcy's equation - Chezy's equation(No derivation) – Problems - Transmission of power through pipes – Efficiency - Pipes in parallel connected to reservoir - Discharge formula - Simple problems.

UNIT- 3

20 Hours

3.1 Flow through Notches:

Definitions- Types of Notches – Rectangular, Triangular and Trapezoidal notches – Discharge derivation - Simple problems - Comparison of V-Notch and Rectangular Notch.

3.2 Flow through Weirs:

Definitions- Classifications of weirs- Discharge over a rectangular weir and trapezoidal weir – Derivation – Simple problems – End contractions of a weir – Franci's and Bazin's formula – Simple problems - Cippoletti weir – Problems - Narrow crested weir - Sharp crested weir with free over fall - Broad crested weir - Drowned or Submerged weirs - Suppressed weir - Stepped weir – Problems - Definition of terms - Crest of sill, Nappe or Vein, Free discharge - Velocity of approach – Spillways and Siphon spillway - Definition.

UNIT- 4

20 Hours

4.1 Flow through open channels:

Definition - Classification - Rectangular and Trapezoidal channel –Discharge - Chezy's formula, Bazin's formula and Manning's formula - Hydraulic mean depth – Problems -

Conditions of rectangular/trapezoidal sections - Specific energy, critical depth - Conditions of maximum discharge and maximum velocity - Problems - Flow in a venturiflume – Uniform flow in channels – Flow through a sluice gate – Types of channels - Typical cross-sections of irrigation canals - Methods of measurements of velocities - Channel losses - Lining of canals – Advantages of lining of canals - Types of lining- Cement concrete lining with sketches - Soil cement lining with sketches - LDPE lining.

UNIT – 5

20 Hours

5.1 Ground water:

Aquifer - Water table -Taping of availability of ground water - Open well - Bore well - Types of well construction - Yield of a open well – Equation - Specific Capacity or Yield of well -Test for yield of well – Rain water harvesting methods - Sanitary protections - No problems.

5.2 Pumps

Pumps – Definition - Classification of pumps - Positive displacement pumps and roto-dynamic pressure pumps - Characteristics of modern pumps -Maximum recommended suction, lift and power consumed.

Reciprocating pump - construction detail and working principle - Types - Single acting and Double acting –Slip - Air vessels - Discharge and Efficiency - Problems.

Centrifugal pump – Advantages and Disadvantages over a reciprocating pump - Layout - Construction details – Priming of centrifugal pump - Working of the pump - Classification – Necessity of Foot valve, Delivery valve and Non-return valve - Fundamental equation of centrifugal pump - Characteristics of a centrifugal pump – Discharge, power and efficiency – Problems - Specifications of centrifugal pumps and their sections. Hand pump - Jet pump, Deep well pump - Plunger pumps - Pump section – Piping system.

REVISION AND TEST

12 Hours

Reference Books :

1. P. Sankaran - Hydraulics & Hydraulic Machines - DOTE Publications - Chennai
2. Dr. Jagadish Lal - Hydraulics, Fluid Mechanics and Hydraulic Machines – Metropolitan Book Company- New Delhi
3. P.N. Modi & S.M. Sethi - Fluid Mechanics - Standard Publishers – New Delhi
4. S. Ramamirtham - Hydraulics, Fluid Mechanics and Hydraulics Machines – Dhanpat Rai & Sons – New Delhi
5. R.S. Khurmi - Hydraulics, Fluid Mechanics and Hydraulics Machines – S. Chand & Co – New Delhi
6. K.L.Kumar - Fluid Mechanics – Eurasa Publishing House – New Delhi
7. R.K. Bansal - Fluid Mechanics - Lakshmi Publications
8. Prof. S. Nagarathinam - Fluid Mechanics - Khanna Publishers – New Delhi
9. K.R. Arora - Hydraulics, Fluid Mechanics and Hydraulics Machines – Standard Publishers & Distributors – New Delhi
10. V.B. Priyani - Hydraulics Vol. I & II - Charotar Publishers – New Delhi

ELECTIVE THEORY-II

11081.a.-TOWN PLANNING

6 HOURS/WEEKS

16 WEEKS

96 HOURS

Objectives:

- To understand the principle of Town Planning and surveys.
- Study the requirements of housing and slums.
- Study the requirement of Public buildings, parks and play grounds.
- Preparation of Master plan and Re-planning of existing Towns.
- Knows about Building bye laws and other miscellaneous topics.

UNIT-1

16 Hours

1.1 Town planning principles

General-evolution of planning-objects of town planning-Economic justification for town planning-principles of Town planning-Necessity of town planning-origin of towns-growth of towns-stages in town development-personality of town-Distribution of land uses-Forms of planning-site for an ideal Town-Requirements of new Towns-Planning of the modern Town-Powers required for enforce T.P. schemes-cost of Town planning-present position of Town Planning in India.

1.2 Surveys

General-Necessity-collection of Data-Types of surveys-Uses of surveys.

1.2 Zoning

Meaning of the term-Uses of land-objects-principles of Zoning-Advantages of Zoning-Importance of Zoning-Aspects of Zoning-Transition Zone-Economy of Zoning-Zoning powers-Maps for Zoning.

UNIT-2

16 Hours

2.1 Housing

General-Importance of housing-Demand for houses-Building site-Requirements of residential buildings-Classification of residential buildings-Design of residential areas-Rural Housing-Agencies for housing-Investment in housing- HUDCO- CIDCO- Housing problem in India.

2.2 Slums

General-Causes of slums-Characteristics of slums-Effects of slums-Slum clearance-Works of improvement-Open plot scheme-Slum clearance and rehousing-Prevention of slum formation-Resources for slum clearance programmes-The Indian slum.

UNIT-3

20 Hours

3.1 Public buildings

General - Location of Public Buildings – Classification of public Buildings - Principles of design of public buildings - Town centres - Grouping of public buildings - Civic aesthetics.

3.2 Parks and play grounds

General-Types of recreation-Location of urban green spaces-clasification of parks-park systems-park design-Finance of parks-parkways-playgrounds-space standards-Landscape architecture.

3.3 Master plan

General-Objects-Necessity-Data to be collected-Drawings to be prepared-Features of master plan-Planning standards-Report-stages of preparation-Method of Execution-conclusion.

3.4 Re-planning existing towns

General-Objects of re-planning-Defects of existing towns-Data to be collected-Urban renewal projects-Decentralization-Garden city-Surface drains-Refuse of Town.

UNIT-4

16 Horus

4.1 Urban roads

General-Objects- Requirements of good city road-Factors to be considered-Classification of urban roads-Types of street systems-Through and By-pass roads-Outer and inner ring roads-Expressways- Freeways-Precincts-Road aesthetics.

4.2 Traffic management

General-Object-Traffic survey-Traffic congestion-Traffic control-Road junction-Parking-Traffic capacity of road-Road traffic problems –Road accident-Traffic signal –Road sign – Road marking-Street lighting in a town –Traffic pr4oblem of existing towns –Peculiarities of traffic.

UNIT-5

16 Hours

5.1 Building bye-laws

General- Objects of bye-laws-importance of bye-laws-Function of local authority-Responsibility of owner-Applicability of bye-laws-set-back-Light plane-Floor space index-Off-street parking-Fire protection-Minimum plot sizes-Some other terms-Principles underlying building bye-laws-Building bye-laws for residential area of a typical town planning scheme-Building bye-laws-Development control rules- General rules of metropolitan Area-CMDA rules.

5.2 Miscellaneous topics

Airports-Location-size-Noise control-Parts of an airports-Betterment and compensation-city blocks-conurbations-Cul-de-sac streets-Focal point-Green belt-Public utility services-Rapid transit –Remote sensing application –urban planning using remote sensing-site suitability analysis-Transportation planning.

REVISION AND TEST

12 Hours

Reference Books :

1. K.S.Rangwala and P.S.Rangwala, "Town Planning", Charotar Publishing House, 15th Edition, 1999.
2. Michael Hord, R. Remote sensing methods and application, John Wiley and Sons, New York, 1986.
3. National Building Code of India- Part-III.
4. Municipal and Panchayat bye-laws, CMDA Rules and Corporation bye-laws.
5. KA. Ramegowda, Urban and regional planning, University of Mysore
6. M/s DVan, The urban pattern, city planning and design.
7. Time saver standards for site planning, Mc Graw Hill Book company
8. John Rate life, An Introduction to town and country planning, London
9. The art of home landscaping – Mc Graw Hill Book company
10. Harvey M. Rubenstein, A Guide to site and Environmental planning, New York.

1082.b.-WATER RESOURCES MANAGEMENT

6Hours/week

16 weeks

96 Hours

Objectives:

- To understand the need and mode of irrigation and water resources management
- To understand the components of the hydrological cycle
- To understand the distribution of ground water, evaluation of aquifer development of ground water methods.
- To understand the GIS application for ground water management.
- To understand the River basin and management.
- To study the major rivers in India and Tamil Nadu.
- To know the irrigation water management.
- To understand the Distribution system of canals.
- To understand the concept of water shed management.
- To understand about the farm Ponds.
-

UNIT-I

16 Hours.

1.1 Introduction :

Water resources -Importance of water resources- Necessity for conservation and development of water resources - water resources management purpose water budget - India's water resources - factors involved in water resources management.

1.2.Hydrology:

Introduction -Hydrology and its importance- Hydrological cycle- Precipitation and its forms -measurements of rain fall-Rain gauges and its types -Measurements of rainfall using Satellite - Radar measurements- runoff -factors affecting runoff -Estimation of runoff -losses - Hydrograph-uses.

UNIT-II

17 Hours

2.1 Ground water:

Ground water resources- Subsurface water- factors affecting resources -Aquifer and its types- terms used - Specific capacity -coefficient of storage -yield permeability -Darcy's law - measurement of yield of under ground sources-pumping test-Evaluating ground water resources and investigations and its methods-Electrical resistivity method - Artificial recharges and its methods.

2.2 Applications of gis:

Aerial assessment of surface water bodies - Flood risk zone mapping - identification of ground water potential zones - recharge areas -Drought- definitions -Drought assessment and management.

UNIT -III

17

Hours

3.1.River basin management:

River basin systems- water rights and water allocation system-water quality management-Eco system management - Major rivers and reservoirs system in India- Tamil nadu - Inter linking of rivers and its importance .

3.2 River training works :

Necessity marginal Embankments - Guide banks -Crayons- types - Pitching of Banks.

3.3.Storage works :

Surface storage-Reservoirs -tanks -purpose of surface storage - Dam - types-lakes - lake basin -storage capacity of reservoir-Evaporation and absorption losses-site selection for a dam - types -spillway- gates -types-sluices-types -Earth dams-types -Failure and remedial measure.

UNIT-IV

17 Hours

4.1 Irrigation water management :

Introduction - objectives of water management- components of water management-optimum use of water & its needs -minimizing irrigation water and its losses -On farm development works-percolation ponds -participatory irrigation management-water users association-cropping pattern -need for crop rotation- Factors affecting crop water requirement- irrigation schedules- Time of irrigation - critical stages of water need of crop - frequency of irrigation.

4.2 Distribution works:

Canal alignment - types of canals - distribution system of canals - Typical cross section of canals - terms used in canals-losses from canals -type and prevention-lining of canals- Necessity -types of lining - water drainage of lined canal- cross drainage works -types control structure- silt center measures- silt excluder - silt ejector- control point and their location-canal drops- need.

UNIT-V

17 Hours

5.1 Water shed management:

Introduction - concept and frame work-water shed approach - Soil and water conservation - Necessity soil erosion - erosion problems - conservation technology- Mechanical measures for erosion control - contour cultivation -contour bunding drainage of excessive water-methods maintains of contour bunding -bench terracing -types-Grassed water way- definition-purpose-control of gullies.

5.2 Water harvesting and recycling:

Introduction - runoff collection - onsite detention basin - ponds -selection of pond site - Embankment ponds- excavated ponds -Seepage control - methods-evaporation control- Recycling of harvested water- Drainage and Reclamation of water logged lands-sewage irrigation- conservation forestry-water shed management -case study.

REVISION AND TEST

12 Hours

REFERENCES:

1. Santhosh Kumar, Garg, Hydrology and water resources engineering,-
2. R.K.Sharma, T.K.Sharma, Irrigation Engineering ,
3. Ralph A.Warbs, Wesley P.James, Water Resources Engineering ,
4. Raghunath H.M.,Ground water Hydrology
5. Dilip Kumar Majumdar, Irrigation water management -, Principles and Practice

Hall of India Pvt.Ltd.NewDelhi-2.

6. V.Vdhruva Narayana, C.Sastry, V.S.Patnaik ,Water shed Management-.
7. P.A.Burrougu , Principles of GIS for land resources assessment, -Oxford publications 2000.
8. Michael Hord R,John Wey and sons, Remote sensing method and applications , ,Newyork 1986.

11064 - HYDRAULICS & PLUMBING LABORATORY PRACTICE.

3 Hours/ Week

16 Weeks

48 Hours

Objectives:

1. Verify Bernoulli's theorem experimentally.
2. Determine the Co-efficient of Venturi meter, Orifice meter, Orifice, Mouthpiece and Notches.
3. Determine Friction factor for the given GI pipe/PVC pipe.
4. Draw characteristics curves for Reciprocating pump and Centrifugal pump.
5. Identify Pipe fittings and Sanitary fittings.
6. Make bathroom connection, Suction and Delivery pipe connection using GI pipes/PVC pipes.

HYDRAULICS LAB

Experiments

32 hours

1. Measurement of Fluid Pressure using Manometers and Pressure Gauges.
2. Verification of Bernoulli's theorem.
3. Flow through Venturimeter – Determination of Co-efficient of Discharge.
4. Flow through Orificemeter – Determination of Co-efficient of Discharge.
5. Setting of Rain Gauge in the campus and methods of measuring the Rainfall as per standard Norms may be explained to the students and Rain fall Records may be maintain in the Laboratory for reference.

Flow through orifice :

6. Determination of Co-efficient of Discharge by Timing fall in head method
7. Determination of Co-efficient of Discharge by Constant head method

Flow through external cylindrical mouth piece :

8. Determination of Co-efficient of Discharge by Timing fall in head method
9. Determination of Co-efficient of Discharge by Constant head method

Flow through pipes :

10. Determination of friction factor for the given GI pipe / PVC pipe.

Flow through notch :

11. Determination of Co-efficient of Discharge for Rectangular Notch / V-Notch

Pumps :

- 12. Reciprocating pump – To draw characteristic curves.
- 13. Centrifugal pump – To draw characteristic curves

PLUMBING LAB

Exercises 10 hours

1. Identifying Pipe fittings used in water supply and Sanitary Wares.
(with actual models displayed on board- Examination Viva voce only)
2. Cutting, Threading and Joining of G.I. pipes/ Cutting and Pasting of PVC pipes using Solvents.
3. Making a Bathroom connection from an existing Water supply Main (making Indents, drawing a neat sketch of the connection with details).
4. Making Suction and Delivery pipe connections to a centrifugal pump (making Indents, drawing a neat sketch of the connection with details).

Revision & Test

6 hours

Note : In the examination the students have to be given **one** experiment from Hydraulics Lab (45 marks) and **one** exercise from Plumbing Lab (25 marks).

Reference Books :

1. Hydraulic Lab Manual Compiled - T.T.T.I. - Chennai – 113.
2. Ghosh and Talapohia - Experimental Hydraulic - Khanna Publishers - New Delhi

LIST OF EQUIPMENTS REQUIRED

HYDRAULICS LAB

- | | |
|--|---------|
| 1. Apparatus to verify Bernoulli's Theorem | - 1 set |
| 2. Apparatus for determining co-efficient of discharge Venturimeter and Orificemeter | - 1 set |
| 3. Apparatus for determining co-efficient of discharge of Orifice | - 1set |
| 4. Apparatus for determining co-efficient of discharge of Mouthpiece | - 1set |
| 5. Apparatus for determining the Pipe Friction | - 1 set |
| 6. Apparatus for determining co-efficient of discharge of Rectangular/ V Notch | - 1 set |
| 7. Reciprocating Pump Test Rig | - 1 set |
| 8. Centrifugal Pump Test Rig | - 1 set |

PLUMBING LAB

1. Pipe fitting Display board (GI/PVC) – Consisting of all Fittings, Pipes, Specials & Valves of different sizes in sufficient quantity.
- 1 No.

2. Sanitary fitting display board - Consisting of Bath tubs, Flushing cisterns, Sinks, Drinking fountain, Wash basin, Urinals and Water closets of different sizes in sufficient quantity.

- 1 No.

3. Tools required for Cutting, Threading and Making Bath room connection & Suction and Delivery Pipe Connections -

- ❖ Pipe Vice : Size 50 mm
- ❖ Chain Pipe Vice
- ❖ Bench Vice : Size 100 mm / 150mm
- ❖ Pipe Die sets of sizes ½" to 2"
- ❖ Adjustable Hacksaw frame with Blades 10" or 12"
- ❖ Three wheel pipe cutter 2"
- ❖ Pipe wrench 12", 14", 18" & 24"
- ❖ GI pipes with Specials of different sizes in sufficient quantity
- ❖ PVC pipes with Specials of different sizes in sufficient quantity

11065 - COMPUTER APPLICATION IN CIVIL ENGINEERING

6 Hours/Week

16 Weeks

96 Hours

Objectives:

- Exercises on typical problem using formula bar in M.S.Excel. or open office
- Generation of structural drawings using available **Detailing software package only.**
- Analysis and design problems in R.C.C using available computer package
- Exercises on simple projects using M.S.Project

1. Using MS Excel carryout typical problems involving estimation, analysis and design problems. **24**

Hours.

- a. Prepare the Estimate sheet with Given data (provide all the measurement details) and calculate the Quantity using formula bar.
- b. Prepare the Abstract Sheet for the given data and Calculate Amount and Total Amount using Formula bar.(use separate column for rates and units)
- c. Design and Analysis problems in Excel
 - i.) Given P, L, Diameter, E and Calculate Area and Elongation using Formula bar.

- ii.) Given b, f_{ck}, F_y and M_u then Calculate Effective depth 'd' and Area of Steel ' A_{st} ' using Formula Bar

$$d = \sqrt{M_u / (Q_u b)}$$

$$Q_u = 0.36 f_{ck} k (1 - 0.42 k), \quad K = X_{umax} / d \text{ from table or}$$

$$M_u = 0.87 f_y A_{st} (d - 0.42 \cdot 0.87 f_y A_{st} / 0.36 f_{ck} b)$$

$$a = 0.87 \cdot 0.87 f_y A_{st} \cdot 0.42 / (0.36 f_{ck} b), \quad b = -0.87 f_y d, \quad c = M_u$$

$$A_{st} = (-b - \sqrt{b^2 - 4ac}) / (2a)$$

- iii) Find Ultimate Load on Column for given f_{ck} , Dia& No. of steel rod, and size of column. And Generate Tables for same size of column with different dia and no of reinforcement.

$$P_u = (0.4 f_{ck} A_c + 0.67 f_y A_{sc})$$

Size of column	f_{ck}	f_y	No of rods	Dia of rod	Area of steel $\pi \cdot d^2 / 4$	Area of Concrete $A_c = A - A_{sc}$	Ultimate Load $P_u = (0.4 f_{ck} A_c + 0.67 f_y A_{sc})$
230x230	20	415	4	12			

- d. For Given Dimension of Masonry/R.C.C Dam ie. top width, bottom width, height of Dam , height of water, Sp.wt of masonry/R.C.C. , Sp.wt of Water etc,. Find the Base pressure and check the stability of the Dam.

Note : In addition to the above students may be given similar exercises for practice.

2. Detailed drawing generation for given specification and Bar Bending Schedule using available R.C.C Detailing Package Only, for the following works.

24 Hours.

Students should not draw drawings directly using AutoCad package they should use only available R.C.C Detailing packages. (Example: CADS RC: Reinforced Concrete Detailing Software with AutoCAD Environment, etc.)

- a. Cross section of a Lintel cum Sun Shade.
 - b. Plan and section of a column and Footing (square footing)
 - c. Plan and sectional view of One-Way slab.
 - d. Longitudinal Section and cross section of Singly Reinforced Beam.
3. Carry out the analysis and design of RCC structures (single storey buildings, school etc) using available Software Packages.(Struds on Windows, STADD PRO, CADS A3D.,etc)

**24
Hours.**

Note: Struds on windows, Analysis and design package, student version is available on free of cost contact : Email: iramajeyam2000@yahoo.com

4. Develop the CPM/PERT Network for the Proposed simple Building Project using MSProject.

12

Hours

For all the exercise student should maintain observation note book for all the introduction about the packages used and input data generation about the packages with examples and necessary out put may be taken out from the packages for all the exercises and record note book may be maintained like other laboratories.

**Revision & Test
Hours**

12

Reference

1. Rebecca J.Fiala, M.S.Office2000, Quick Reference Guide, BPB Publications , New Delhi, 2001.
3. Struds on Window, Design Software packages, SoftTech Engineers Pvt. Ltd, www.softtech-engr.com
4. CADS RC: Reinforced Concrete Detailing Software with AutoCAD Environment { CADS RC is a program designed to make detailing and listing of reinforcement in Bar Bending Scheduled (BBS) within the AutoCAD environment accurate and cost effective. Some of the key features that CADS RC Version 9.01 provides include the following: Easy to use and fully integrated with AutoCAD, Detailed drawing generation for Beam, Column, Foundation, Slab, Stair case, Pile CAP, Bar schedules to IS 2502 and SP34 , Detailing links from RC design software like CADS A3D, STAAD etc., Students may get more Job opportunity if they get more practice on preparation of drawing using any one detailing packages.} For further details **Please write to, for installation & training purpose to sales@cadsindia.com ; visit the website www.cads.in or call on 044-28233681/82/83/84 ; 9444017779 ; fax to 044-28232349.**
5. DRAFT AID – ENSOFT SYSTEMS PVT LTD. E-Mail: info@ensoftindia.com Web: www.ensoftindia.com
6. Decaplot – www.decaplot.com

7. RISA-3D –www.risaindia.com –
8. StruCad + StruM.I.S.net – www.acecadsoftware.com sales@acecadsoftware.com

11066 – PROJECT WORK

6 HOURS/WEEK

16 WEEKS

96 HOURS

Objectives: The Student should apply the various concepts of Civil Engineering that they have studied in the curriculum and referring the various journals and magazine etc., and they should select suitable civil engineering project and prepare the report.

Instruction:

The objective of the project work is to enable the students to work in convenient groups of not more than six members in a group on a project involving theoretical and experimental studies related to Civil Engineering. Every Project Work shall have a Guide who is a member of the faculty of Civil Engineering of the college. The hours allotted for this course shall be utilized by the students to receive directions from the Guide, on library reading, laboratory work, computer analysis or field work and also to present in periodical seminars the progress made in the project.

Each student shall finally produce a comprehensive report covering background information, literature Survey, problem statement, Project work details and conclusions.

This experience of project work shall help the student in expanding his / her knowledge base and also provide opportunity to utilise the creative ability and inference capability.

WORKS INVOLVED IN PROJET WORK:

Collection of Data from various Journals and Civil Engineering Magazines about the list of Projects given below- Select a suitable project based on the data collected and available resources in your locality -Surveyed Site Plan – Site particulars – Preparation of Architectural Drawings – soil type in the location – Specification for materials & construction procedure - Structural design – Preparation of Detailed Estimate, Data as per Current schedule of Rates and Abstract Estimate – Structural Drawings – Preparation of Report about the project.

IMPORTANT DOCUMENTS TO BE REFERRED FOR THE ABOVE ACTIVITIES:

Sl. No	Activity	Reference
1	Preparation of Architectural Drawings	1. Building Regulations of Locality 2. National Building Code , etc.
2	Structural design	1. Relevant IS code for masonry, steel structures etc.

		<ol style="list-style-type: none"> 2. IS 456 for Reinforced Cement Concrete. 3. Hand book on detailing for reinforcement (SP-34)
3	Specification of material and work procedure	<ol style="list-style-type: none"> 1. Construction procedure by State Govt. organization viz. PWD , Highways, etc. 2. Construction procedure by Central Govt. organization viz. CPWD , Railways, etc. 3. Specification by Architect

Important Note: 20 marks allotted for written test on Ten short questions in the above topics.

DISASTER MANAGEMENT:

- (a) Introduction – Major Disaster – Floods- Planning for flood Protection – Management of Floods- Mitigation – Rehabilitation – community awareness – Earth quakes – Safety measures- During and after the earth quake- Cyclone – safety precaution before 16 hours and 6 hours away – precaution when cyclone has passed – Tsunami – when tsunami encounters land – safety precautions - Man made Disasters – Crisis due to fires, accidents, strikes etc – Loss of property and life.
- (b) Disaster Mitigation measures – Causes for major disasters – Risk Identification – Hazard Zones – Selection of sites for Industries and residential buildings – Minimum distances from Sea – Orientation of Buildings – Stability of Structures – Fire escapes in buildings - Cyclone shelters – Warning systems.
- (c) Disaster Management – Preparedness, Response, Recovery – Arrangements to be made in the industries / factories and buildings – Mobilization of Emergency Services - Search and Rescue operations – First Aids – Transportation of affected people – Hospital facilities – Fire fighting arrangements – Communication systems – Restoration of Power supply – Getting assistance of neighbours / Other organizations in Recovery and Rebuilding works – Financial commitments – Compensations to be paid – Insurances – Rehabilitation – safe construction practices.

Important Note: 10 marks allotted for written test on Five short questions in the above topics.

LIST OF SUGGESTED PROJECTS

COMPARITIVE STUDY

- Conventional and Composite concrete mixtures
- Light weight construction materials
- Prefabricated and R.C.C. Structures

- Cost and construction procedures for steel and R.C.C. Structures
- Cost and Construction procedures for Prestressed and R.C.C. Structures

ADMIXTURES

- Economy of using flyash in concrete

MIX DESIGN

- Comparative study of mix design by different methods

SPECIAL TYPES OF CONCRETE CONSTRUCTION

- Bamboo as a reinforcing material
- Ferro cement products – water Tanks, Septic tank
- Fibre reinforced concrete
- Self Compacting concrete

PAPER PROJECTS

- Residential Houses
- Primary Health center
- School Buildings
- Guest House
- Panchayat Union Office Building.
- Bank Building
- Post Office Building
- College Building
- Hospital Building
- Hotel Building
- Hostel Building
- Factory Building
- Auditorium
- Shopping Centre
- Community Hall
- Theatre
- Market Building
- Multistoried Car park
- Rural Bus Stand
- Stadium
- Swimming Pool
- Over head tank for a village
- New village road with culvert
- Small Bridge
- Plate girder bridge
- Septic Tank for a Colony

ENVIRONMENTAL MANAGEMENT PROJECTS

- Treatment of Wastewater and recirculation for a Colony.
- Solid waste management in a Colony.
- Hydrological data Collection for a river basin/water shed
- Industrial effluent Collection and analysis .

MISCELLANEOUS

- Using Factory waste (such as steel, flyash, thermo cool etc) as substitute for Building materials
- Low cost Housing
- Rehabilitation of structures

CIVIL ENGINEERING

Important I.S.Codes and Hand Books

1. SP 16 : 1980 Design Aids for Reinforced Concrete to IS 456 : 1978
2. SP 23 : 1982 Handbook on Concrete Mixes
3. SP 24 (S and T) : 1983 Explanatory Handbook on Indian Standard Code of Practice for Plain and Reinforced Concrete
4. SP 25 : 1984 Handbook on Causes and Prevention of Cracks in Buildings
5. SP 62 (S and T) : 1997 Handbook on Building Construction Practices (Excluding Electrical Work)
6. SP 34 : 1987 Handbook on Concrete Reinforcement and Detailing
7. IS 456 : 2000 Plain and Reinforced Concrete - Code of Practice
8. IS 1343 : 1980 Code of Practice for Prestressed Concrete
9. IS 1489 : Part 1 : 1991 Specification for Portland pozzolana cement Part 1 Flyash based
10. IS 2386 : Part I : 1963 Methods of Test for Aggregates for Concrete - Part I : Particle Size and Shape
11. IS 2386 : Part 3 : 1963 Methods of test for aggregates for concrete Part 3 Specific gravity, density, voids, absorption and bulking
12. IS 2386 : Part 4 : 1963 Methods of test for aggregates for concrete Part 4 Mechanical properties
13. IS 2502 : 1963 Code of Practice for Bending and Fixing of Bars for Concrete Reinforcement
14. IS 2645 : 1975 Specification for Integral Cement Waterproofing Compounds
15. IS 3370 : Part 1 : 1965 Code of practice for concrete structures for the storage of liquids: Part 1 General requirements
16. IS 3370 : Part 2 : 1965 Code of practice for concrete structures for the storage of liquids: Part 2 Reinforced concrete structures
17. IS 3812 : 1981 Specification for fly ash for use as pozzolana and admixture
18. IS 5525 : 1969 Recommendations for Detailing of Reinforcement in Reinforced Concrete Works
19. IS 8112 : 1989 Specification for 43 grade ordinary Portland cement
20. IS 9103 : 1999 Concrete Admixtures - Specification
21. IS 10262 : 1982 Recommended guidelines for concrete mix design
22. IS 12269 : 1987 Specification for 53 grade ordinary Portland cement
23. IS 1237 : 1980 Specification for Cement Concrete Flooring Tiles
24. IS 1443 : 1972 Code of practice for laying and finishing of cement concrete flooring tiles
25. IS 2571 : 1970 Code of practice for laying in-situ cement concrete flooring
26. IS 5491 : 1969 Code of practice for laying of in-situ granolithic concrete flooring topping
27. IS 6278 : 1971 Code of Practice for Whitewashing and Colour-washing
28. IS 1346 : 1991 Code of Practice for Waterproofing of Roofs with Bitumen Felts
29. IS 1609 : 1991 Code of practice for laying damp-proofing treatment using bitumen felts.
30. IS 3036 : 1992 Code of practice for laying lime concrete for a waterproofed roof Finish
31. IS 3067 : 1988 Code of practice for general design details and preparatory work for damp-proofing and water-proofing of buildings
33. IS 13727 : 1993 Guide for requirements of cluster planning for housing
34. IS 14213 : 1994 Code of practice for construction of walls using precast concrete stone masonry blocks
35. IS 8888 : Part 1 : 1993 Guide for requirements of low income housing Part 1 Urban area
36. IS 1200 : Part 1 : 1992 Methods of measurement of building and civil engineering works: Part 1 Earthwork
37. IS 1200 : Part 17 : 1985 Method of measurement of building and civil engineering works: Part 17 road work including air field pavements

38. IS 3861 : 2002 Method of Measurement of Plinth, Carpet and Rentable Area of Buildings
39. IS 1904 : 1986 Code of practice for design and construction of foundations in soils: general requirements
40. IS 2720 : Part 5 : 1985 Method of Test for Soils - Part 5 : Determination of Liquid and Plastic Limit
41. SP 22 : 1982 Explanatory Handbook on Codes for Earthquake Engineering
42. IS 1893 : Part 1 : 2002 Criteria for Earthquake Resistant Design of Structures - Part 1 : General Provisions and Buildings
43. IS 1893 : 1984 Criteria for earthquake resistant design of structures
44. IS 4326 : 1993 Code of practice for earthquake resistant design and construction of buildings
45. IS 13935 : 1993 Guidelines for repair and seismic strengthening of buildings
46. IS 13920 : 1993 Ductile detailing of reinforced concrete structures subjected to seismic forces - Code of practice
47. IS 875 : Part 1 : 1987 Code of practice for design loads (other than earthquake)for buildings and structures Part 1 Dead loads - Unit weights of building material and stored materials (Incorporating IS:1911-1967)
48. IS 875 : Part 2 : 1987 Code of practice for design loads (other than earthquake) for buildings and structures: Part 2 Imposed loads
49. IS 875 : Part 3 : 1987 Code of Practice for Design Loads (Other than Earthquake) for Buildings and Structures - Part 3 : Wind Loads
50. IS 875 : Part 4 : 1987 Code of practice for design loads (other than earthquake) for buildings and structures Part 4 Snow loads
51. IS 1641 : 1988 Code of practice for fire safety of buildings (general): General principles of fire grading and classification
52. IS 1642 : 1989 Code of practice for fire safety of buildings (general): Details of construction
53. IS 1643 : 1988 Code of practice for fire safety of buildings (general): Exposure hazard
54. IS 1644 : 1988 Code of practice for fire safety of buildings (general): Exit requirements and personal hazard
55. IS 1646 : 1997 Code of practice for fire safety of buildings (general): Electrical installations
56. IS 3034 : 1993 Fire Safety of Industrial Buildings: Electrical Generating and Distributing Stations - Code of Practice
57. IS 14435 : 1997 Code of practice for fire safety in educational institutions
58. IS 1477 : Part I : 1971 Code of Practice for Painting of Ferrous Metals in Buildings - Part I : Pretreatment
59. IS 2395 : Part 1 : 1994 Painting of Concrete, Masonry and Plaster Surfaces - Code 60.of Practice - Part 1 : Operations and Workmanship
61. IS 14428 : 1997 Guidelines for painting of structures in aggressive chemical environment
62. IS 204 : Part 1 : 1991 Specificaion for tower bolts: Part 1 Ferrous metals
63. IS 281 : 1991 Mild Steel Sliding Door Bolts for Use with Padlocks - Specification
64. IS 1495 : 1970 Specification for mild steel dust-bins
65. IS 5899 : 1970 Specification for Bath-room Latches
66. IS 4130 : 1991 Safety code for demolition of buildings
67. IS 13430 : 1992 Code of practice for safety during additional construction and alteration to existing buildings
68. SP 35 : 1987 Handbook on Water Supply and Drainage (with Special Emphasis on Plumbing)
69. IS 1172 : 1993 Code of Basic Requirements for Water Supply, Drainage and Sanitation
70. IS 1742 : 1983 Code of practice for building drainage
71. IS 4127 : 1983 Code of practice for laying of glazed stoneware pipes
72. IS 10313 : 1982 Requirements for settling tank (clarifier equipment) for water treatment plant
73. IS 962 : 1989 Code of practice for architectural and building drawings

74. IS 1553 : 1989 Design of Library Buildings - Recommendations Relating to its Primary Elements
75. IS 4878 : 1986 Byelaws for construction of cinema buildings
76. IS 7973 : 1976 Code of practice for architectural and building working drawings
77. IS 516 : 1959 Method of test for strength of concrete
78. IS 650 : 1991 Specification for standard sand for testing of cement
79. IS 2212 : 1991 Code of practice for brickwork
80. IS 3548 : 1988 Code of Practice for Glazing in Buildings
81. IS 11134 : 1984 Code of practice for setting out of buildings

11061.CONSTRUCTION MANAGEMENT WITH MIS

MODEL QUESTION PAPER- I

Max Mark : 75

Duration : 3 Hrs

- Note :** 1 Answer ALL QUESTIONS from **PART - A** each carrying 1Mark
2 Answer ALL QUESTIONS from **PART - B** each carrying 3Marks
3 Answer ALL QUESTIONS from **PART - C** choosing either a or b each carrying 10 Marks

PART- A (10 x 1 = 10)

1. Define Tender.
2. What are the objectives of planning
3. Expand P.W.D and C.P.W.D
4. Define the term bill.
5. What does scheduling mean?
6. Define Resource Management
7. What are the causes of accident.
8. Define entrepreneurship.
9. What is rural banking.
10. What is meant by cash outflow?

PART- B (5 x 3 = 15)

11. a. List any two types of contract b. State any two objectives of planning.
12. a. State any two responsibility of contractor. B. Write any two engineering organization in TamilNadu.
13. What do you understand the term 'Nominal Muster Roll'?
14. List the causes of accident
15. Define MIS.

PART- C (5 x 10 = 50)

16. a Explain briefly the role of government and construction agencies.
(or)

- b Write short notes on:
 - (i) Earnest Money Deposit' and
 - (ii) Security Deposit

- 17.a Write short notes on:
 - (iii) Sole Proprietorship and
 - (iv) Co-operative society.

(or)

- b Describe the procedure of preparation and examination and payments of bills for work done.

- 18.a A construction project involves the following activities. Draw the **Network** Diagram. Mark the critical path. What is the project time?

Activity	0-1	0-2	1-3	2-3	3-4	4-5	4-6	5-6	2-6
Duration in Days	18	4	5	4	6	6	8	8	12

(or)

- b. Write short notes on:
 - (i) Material Schedule
 - (ii) Resource Levelling

19.a .Explain briefly the provision of factory act with reference to health, safety and welfare

of workers. (or)

b. Write in detail about **SISI** and **DIC** role in the development of entrepreneurship programmes.

20. a Explain in detail about project management and operations simulation packages.

(or)

b. A firm with 10% cost of Capital is considering to Invest in a new machine with an expected life of 6 years. The cash flows resulting from this investment are as

follows:

Initial Investment: Rs.1 Lakh.

Cash Inflow: Year	Cash Inflow (Rs.)	P.V.Factor
1.	30,000	0.909
2.	16,000	0.826
3.	20,000	0.751
4.	24,000	0.683
5.	28,000	0.621
6.	32,000	0.564

Determine the Profitability Index, Net present value and also state whether the project

can be Undertaken or Rejected.

11061.CONSTRUCTION MANAGEMENT WITH MIS

MODEL QUESTION PAPER-II

Max Mark : 75

Duration : 3 Hrs

- Note :** 1 Answer ALL QUESTIONS from **PART - A** each carrying 1Mark
2 Answer ALL QUESTIONS from **PART - B** each carrying 3Marks
3 Answer ALL QUESTIONS from **PART - C** choosing either a or b each carrying 10 Marks

PART- A (10 x 1 =10)

1. Define contract.
2. State any two objectives of planning.
3. Define the term voucher.
4. What is the purpose of Measurement Book.
5. What is resource management?
6. Define specification.
7. Define the term standard deviation.
8. What is meant by cash inflow?
9. Write the basic concept of estimation.
10. Name any two types of bank.

PART- B (5 x 3 =15)

11. a. List any two types of construction. b. Define Tender Documents.
12. Define ethics and integrity.
13. Define C.P.M and Explain the significance of critical path.
14. What is the role of various party in safety management.
15. Explain IRR method.

PART- C (10 x 5 =50)

- 16.a. Explain briefly the role of government and construction agencies.
(or)
b What are the procedures to be followed in scrutiny of tenders and acceptance of a tender?
- 17.a. Write short notes on:
(i) State Enterprises and
(ii) Multidisciplinary capability.
(or)
b. Explain briefly about the following:
(i) Imprest cash account
(ii) Nominal muster roll
18. a. The following are the three time estimates of activities. Compute the average expected time for each activity. Draw the Project Network. Calculate T_E , T_L and Slack for each node. Identify the critical path. What is expected project length?

Duration in Days	Activity	1-2	1-3	1-4	2-5	3-5	4-6	5-6
	T_O	1	1	2	1	2	2	3
	T_L	1	4	2	1	5	3	6
	TP	7	6	8	1	14	10	15

(or)

b. Write short notes on:

- (i) Work Breakdown Chart (WBC)
- (ii) Time Vs Cost optimization curve

19.a. Write short notes on:

- (iii) Industrial Disputes Act 1947
- (iv) Employees Provident Fund

(or)

b. Explain in detail about risks and rewards of entrepreneurship.

20.a Explain briefly about a data base approach to contractor's account and its advantages.

(or)

b. An equipment required an initial investment of Rs.15, 000. The annual cash flow is estimated at Rs.3,000 for 5 years. Calculate the internal rate of return. (Using Table-II)

11062 – HYDRAULCS

MODEL QUESTION PAPER- I

Max Mark : 75

Duration : 3 Hrs

- Note :**
- 1 Answer ALL QUESTIONS from **PART - A** each carrying 1Mark
 - 2 Answer ALL QUESTIONS from **PART - B** each carrying 3Marks
 - 3 Answer ALL QUESTIONS from **PART - C** choosing either a or b each carrying 10 Marks

PART – A (10 x 1 = 10)

1. State the relationship between Absolute pressure, Atmospheric pressure and Gauge pressure.
2. What is the absolute pressure in KN/m^2 when the vacuum pressure at a point is 2 m of water.
3. Write the equation of Bernoulli's theorem.
4. Distinguish between Laminar flow and Turbulant flow.
5. State the difference between a notch and a weir.
6. Distinguish between Narrow crested weir and Broad crested weir.
7. State the condition for an economical rectangular section.
8. What are the types of lining of canal
9. Define the terms : Acquirer and Water table.
10. Dhat is the effect of fixing Air vessel in a pipe line?

PART – B (5 x 3= 15)

11. Define: Cohesion, Capillarity, Total pressure and Centre of pressure.
12. State different types of orifices, Mouthpieces and What are the Major and Minor losses of head ?
13. Mention different types of Notches and their discharge formulas. and What is a Siphon spillway ? State its application.
14. Define the terms : Wetted perimeter and Hydraulic mean depth. and What is uniform flow in an open channels.
15. Write short note on Jet pump and State the specifications of a Centrifugal pump.

PART – C (10 x 5 = 50)

- 16 a). A simple manometer is used to measure the pressure of oil of relative density 0.75 flowing in a pipe line. Its right limb is open to the atmosphere and the left limb is connected to the pipe. The centre of pipe is 0.10m below the mercury in the right limb. If the difference of mercury level in the two limbs is 0.20m, determine the absolute pressure of oil in the pipe in Pa.
- Or
- b). A rectangular plate 2m x 3m is immersed vertically in water such that the top 2m is parallel to and at a depth of 1m below the free water surface. Compute the total pressure on one side of the plate and depth of centre of pressure.
- 17 a). The discharge through a vertical water pipe of length 1.2m, 100mm diameter at top and 200mm diameter at bottom is 78.54 lps. If the intensity of pressure at the bottom is $98.1 \times 10^3 \text{Pa}$. Find (i) the velocity at top, (ii) the velocity at bottom, and (iii) the pressure at

top.

Or

- b). Water flows through a 150mm diameter and 50m long pipe with a velocity of 3m/s. Find the loss of head by using –
- (i) Darcy's formula, taking friction factor as 0.02.
 - (ii) Chezy's formula, taking Chezy's constant as 60.

- 18 a). A trapezoidal notch is 1.5m wide at the top and 0.75m at the bed. The height is 0.45m. Determine the discharge through the notch when the head of water is 0.30m. Take C_d as 0.6.

Or

- b). A rectangular weir 6m long is divided into 3 equal bays by two vertical posts, each 0.3m thick. Find the discharge when the head of water is 0.45m. Allow for end contractions. Take C_d as 0.62.

- 19 a). A rectangular channel is 8m wide and 3m deep. The bed fall is 1 in 1000. Find the discharge, when it is running full. Take Chezy's constant as 0.55.

Or

- b). A rectangular channel has an economical section. The maximum discharge through the channel is $75 \text{ m}^3/\text{s}$. The bed fall is 1 in 1600. Find the dimensions of the channel. Take $C = 50$.

- 20 a). A single acting reciprocating pump has a piston diameter of 300mm and stroke of 200mm. The speed of the pump is 30 r.p.m. and it delivers 6.5 lps. Find C_d and %Slip.

Or

- b). A centrifugal pump is required to lift 4 m^3 of water per second to a height of 5m. If the total loss of head is 0.4m, compute the maximum power of the motor to run the pump. Efficiency of the pump and motor are 75% each.

11062 - HYDRAULICS

MODEL QUESTION PAPER-II

Max Mark : 75

Duration : 3 Hrs

- Note :**
- 1 Answer ALL QUESTIONS from **PART - A** each carrying 1Mark
 - 2 Answer ALL QUESTIONS from **PART - B** each carrying 3Marks
 - 3 Answer ALL QUESTIONS from **PART - C** choosing either a or b each carrying 10 Marks

PART – A (10 x 1 = 10)

1. List the pressure measuring devices.
2. Mention dimensions and units of Discharge, Pressure and Power.
3. Define three hydraulic co-efficient.
4. Mention Darcy's formula for loss of head in pipes.
5. Where does siphon spillway is used ?
6. What do you mean by end contraction of a weir ? Sketch them.
7. State the uses of Venturiflume.
8. State Bazin's formula for the discharge in the canal.
9. State the expression for Specific yield of a well.
10. Differentiate between Single acting and Double acting reciprocating pumps.

PART – B (5 x 3= 15)

11. How do you find resultant pressure and centre of pressure in Sluice gate.
12. A pipe of 100mm diameter is suddenly enlarged to 200mm. The velocity in 100mm and 200mmdiameter pipes are 7.64m/sec and 1.91m/sec respectively. Find the loss of head due to sudden enlargement.
13. i. Compare V-notch and Rectangular notch. ii. Differentiate between Free nappe and Depressed nappe.
14. i. State different methods of measurement of velocities in open channels. ii. Find the hydraulic mean depth for circular channel of 3m dia. running half full.
15. i. What are the precautions to be taken for the sanitary protection of Wells. ii. What are the Characteristics of a centrifugal pump.

PART – C (10 x 5= 50)

16 . a). A U-tube mercury manometer is connected to inlet and throat of a Venturimeter, fitted in a horizontal pipe, carrying oil of specific gravity 0.8. Find the difference in pressure in Pascals, if the deflection of mercury is 0.25m.

Or

b). A circular plate of 2m diameter is immersed in an oil of relative density 0.8. Its maximum and minimum depths are 2m and 1.2m respectively from free surface . Determine (i) The total pressure on one side of the plate, and (ii) Depth of centre of pressure.

17. a). A rectangular orifice fitted in the side of a large tank is 2.5m broad and 1m deep. The depth of water on the upstream side above the top edge is 1.5m. If the orifice discharges freely into atmosphere, Calculate –

- (i) The discharge using Large orifice formula.
- (ii) The discharge using Small orifice formula.

Or

b). Find the maximum power that can be transmitted through a pipe of 250m long and 75mm diameter. The head of water at inlet of pipe is 40m. Take $f = 0.045$.

18. a). A triangular notch is discharging under a head of 0.50m The angle of the notch is 120° and

C_d is 0.60. Calculate the discharge through the notch.

Or

b). A submerged weir is 3m long. The heads of water on the upstream and downstream sides of

weir are 0.50m and 0.25m respectively. If $C_d = 0.60$, estimate the discharge over the weir.

19. a). A trapezoidal channel is 5m wide at bottom. The side slopes are 1:1. The bed fall is 1 in 1600 and Chezy's constant is 50. Find the discharge, when the depth of flow is 1.1m.

Or

b) i. Derive the conditions for rectangular channel for maximum discharge.

ii. Explain briefly different types of Canal lining.

20. a). A Double acting reciprocating pump having piston diameter of 100mm and stroke of 400mm raises water through a height of 15m. The crank rotates at 60 r.p.m. The discharge is 10 lps. Find – (i) Theoretical discharge, (ii) Slip, and (iii) C_d .

Or

b). i. Explain with a neat sketch, the construction details of a Centrifugal Pump.

ii. Explain the different method of rain water harvesting methods with sketches.

1081.a.TOWN PLANNING

MODEL QUESTION PAPER- I

Max Mark : 75

Duration : 3 Hrs

- Note :** 1 Answer ALL QUESTIONS from **PART - A** each carrying 1Mark
2 Answer ALL QUESTIONS from **PART - B** each carrying 3Marks
3 Answer ALL QUESTIONS from **PART - C** choosing either a or b each carrying 10 Marks

PART -A (10X1=10)

1. Mention the objects of town planning
2. What is the principle of zoning.
3. Classify the residential building
4. What are the methods adopted for slum clearance?
5. What is a garden city?
6. What are the maps required for master plan?
7. What is a sub_ Arterial road
8. What is traffic control?
9. Define built up area?
10. Distinguish plinth area and carpet area

PART-B (5 X 3 =15)

11. Discuss the growth of town according to origin
12. Distinguish natural growth and planned growth
13. What are the factors to be considered while selecting the building site?
14. What are the features to be accompanied with the report of the master plan?
15. What are the details with the application for setting an approval for a building?

PART -C (5 x 10 = 50)

16. a) Discuss the growth of towns according to origin
b) What are the aspects of zoning?
17. a) i.What are the requirements of a residential building?
ii.What are the classification of buildings?
b) i.What are the points to be kept in the selection of a public
ii Explain any one method of slum clearance.
18. a) Write about the various types street system .Explain any one type
b) i Explain urban transport problem
ii.Briefly explain land use health and role of cities
19. a) What are the defects in the existing towns?
b) What are the objects of master plan? Explain the features of master plan?
20. a) 1.What are the object of Bye laws what are principles to be observed while framing the building byelaws?
b) i What are the drawing is to be submitted for plan approval?
ii What are the classification of parks?

1081.b. TOWN PLANNING

MODEL QUESTION PAPER-II

Max Mark : 75

Duration : 3 Hrs

- Note :** 1 Answer ALL QUESTIONS from **PART - A** each carrying 1Mark
2 Answer ALL QUESTIONS from **PART - B** each carrying 3Marks
3 Answer ALL QUESTIONS from **PART - C** choosing either a or b each carrying 10 Marks

PART -A (10X1=10)

1. Mention the objects of town planning.
2. Mention the stages involved in the Lewis Mumford method.
3. Which types of trees can be planted in the clayey soil?
- 2 What are all the types of urban roads?
- 3 Mention the various agencies for housing.
- 4 What are the classifications of industries?
- 5 Write shorts on "land – owners and developers".
- 6 Write shorts notes on "green home".
- 7 What are the drawings submitted to the municipality for approval?

PART - B (5X3=15)

11. What is meant by the term town planning
12. What are the factors considered in the selection of road junction?
13. Write notes on National Housing Policy.
14. Write shorts notes on rapid transport.
15. Enumerate the objects of zoning.

PART - C (10X5=50)

- 16 a) What are the principle of town planning ? Explain in brief
b) What are object of zoning ? what are the advantages of zoning
- 17a) i. What are requirements of a residential building
ii. Explain the advantages of housing finances

b) i. What are the objectives of NHP
ii. Describe the various housing programe by HUDCO
- 18 a) i. State the data to be collected for Replaning of a town
ii. Explain the principles of a Garden city
b) i What is master plan? What are the objects of master plan?
ii List the drawings to be prepared for the master plan
- 19.a). Write short notes on i) Arterial road
ii) Rectangular street system
iii) Elliptical island

b) i. Describe the travel and transport strategy and policy
ii. Explain the transport policy of Tamil Nadu
- 20.a) Write about i) Reforms of Bye laws
ii) Supervising agencies

- b). Write short notes on
- i) set back
 - ii) F.S.I
 - iii) theme park

11082.b. WATER RESOURCES MANAGEMENT

MODEL QUESTION PAPER- I

Max Mark : 75

Duration : 3 Hrs

- Note :**
- 1 Answer ALL QUESTIONS from **PART - A** each carrying 1Mark
 - 2 Answer ALL QUESTIONS from **PART - B** each carrying 3Marks
 - 3 Answer ALL QUESTIONS from **PART - C** choosing either a or b each carrying 10 Marks

PART -A (10X1=10)

1. Write the name of non-recording type rain gauge?
2. Define hydrology.
3. Name any two surface sources
4. Name the different types of aquifer.
5. Name the device used to measure evaporation in a reservoir
6. Name the types of Earth dams.
7. What do you mean by crop rotation?
8. List out the losses from canals.
9. Define run off.
10. What are importance of conservation of forest?

PART – B (10 x 2 =20)

- 11 .What are the necessity for conservation of water ?
12. Define yield of a well.
- 13 Define Ecosystem management.
- 14 Write short note on percolation pond.
- 15 What are the soil erosion problems?

PART - C (5 x 10 = 50)

- 16 a. Explain the various components of a hydrological cycle with a neat sketch
Or
b. Draw a neat sketch of a non recording type rain gauge and Explain its functions.
17. a. i How do you measure the yield of under ground sources ?
ii Explain in detail pumping test
Or
b. i. Explain the various methods of artificial recharge
ii. How do you identify the water bodies using GIS.
18. a. What are the necessities of river training works ?
Explain the marginal embankment with neat sketch .
Or
b. Explain the different types of sluices with neat sketch .
19. a. What are the various components of irrigation water management ?

Or

- b.i What are the necessity of lining of canals ?
- ii Explain different types of lining

20. a. i.Explain contour cultivation and contour bunding
ii. Write about sewage irrigation

or

- b i. Write short note on (a) Grassed water way (b) Terracing
- ii. Explain the different types of ponds